

TABLE OF CONTENTS

CUSTOMER MESSAGE	Inside Front Cover
SAFETY PRECAUTIONS	3
GENERAL DESCRIPTION	6
SPECIFICATIONS	7
MAINTENANCE	9
OPERATION	11
CUTTING SPEEDS AND FEEDS	13
COLLETS	15
TOOL BITS	17
INSTALLATION	18
TROUBLE SHOOTING	20
ACCESSORIES	22
ILLUSTRATED PARTS BREAKDOWN	23
TOOL BIT RESHARPENING POLICY	Inside Back Cover
WARRANTY INFORMATION	Inside Back Cover

Copyright 2007

Proprietary property of TRI TOOL Inc.

No reproduction, use, or duplication of the information shown hereon is permitted without the express written consent of TRI TOOL Inc.

SAFETY PRECAUTIONS

IN GENERAL

When using rotating head cutting equipment, basic safety precautions should always be followed to reduce the risk of personal injury.

Operate this tool only in accordance with specific operating instructions.

WARNING:

Do not override the deadman switch on the power unit. Locking down, obstructing, or in any way defeating the deadman switch on the power drive unit may result in serious injury.

DRESS CONSIDERATIONS

Use standard safety equipment. Hard hats, safety shoes, safety harnesses, protective clothes, and other safety devices should always be used when appropriate.

Use safety glasses. Do not operate cutting tools without eye protection.

Dress properly. Do not wear loose clothing or jewelry. They can be caught in rotating and moving parts. Avoid slippery floors or wear nonskid footwear. If you have long hair, wear protective hair covering to contain it.

WORK AREA

Keep the work area clean. Cluttered work areas and benches invite injuries.

Consider the work area environment. Keep the area well lit. Keep electrical cords, cables, rags, rigging straps, and etc. clear of rotating equipment. Do not use power-cutting tools in the presence of flammable liquids and gasses.

Keep visitors away. Do not let visitors or untrained personnel at or near operating tools. Enforce eye protection requirements for all observers.

Do not over reach. Keep proper footing at all times.

Stay alert. Watch what you are doing. Use common sense. Do not operate tools when you are tired.

TOOL CARE

Maintain tools with care. Keep tools in good operating condition. Sharp tool bits perform better and safer than dull tool bits. Well maintained tools function properly when needed.

Check for damaged parts. If a tool has malfunctioned, been dropped or hit, it must be checked for damage. Run no-load tests and feed function checks. Do a complete visual inspection.

Electric motors. Use only with proper AC voltage power sources and observe all normal electric shock hazard procedures.

Do not abuse power and control cords. Pulling or running over cords and cables can result in electrical shock hazards and malfunctions. Keep control and power cords out of all cutting fluids and water.

Hydraulic drives. Observe proper procedures for electrically driven power sources. Avoid damage to hydraulic lines. Keep quick-disconnects clean. Grit contamination causes malfunctions.

Air tools. Check the exhaust muffler. Broken or damaged mufflers can restrict air flow or cause excessive noise. Use air motors only with a filtered, lubricated and regulated air supply. Dirty air, low-pressure air or over pressure air will cause malfunctions, including delayed starting.

AREA EQUIPMENT

Secure work. Whenever possible use clamps, vises, chains and straps to secure pipe.

Make sure the tool is secured; it is safer to have both hands free to operate the tool.

TOOL USE

Use the right tool and tool bit for the job. Do not use a tool, which is incorrect for the job you are doing.

Keep the tool bits fully engaged in the tool bit holders. Loose bits are a safety hazard.

Disconnect power supply during setup and maintenance. Use all 'Stop' or Shut off' features available when changing or adjusting tool bits, maintaining the tool, or when the tool is not in use.

Remove adjusting keys and wrenches before applying power to the equipment. Develop a habit of checking the tool before turning it on to make sure that all keys and wrenches have been removed.

Do not force tools. Tools and tool bits function better and safer when used at the feed and speed rate for which they were designed.

Do not reach into rotating equipment. Do not reach into the rotating head stock to clear chips, to make adjustments, or to check surface finish. A machine designed to cut steel will not stop for a hand or an arm.

Handle chips with care. Chips have very sharp edges and are hot. Do not try to pull chips apart with our hands; they are very tough.

Avoid unintentional starts. Do not carry or handle tools with your hand on the operating switches or levers. Do not lay the tool down in a manner that will start the drive. Do not allow the tool to flip around or move when adjusting or changing tool bits.

Store idle tools properly. Disconnect tools from the power source and store in a safe place. Remove tool bits for safe handling of the tool.

GENERAL DESCRIPTION

The Model 576AC SEVERMASTER™ severs 2.00" to 6.63" (50.8mm to 168.3mm) diameter tubes and thin wall pipe within the size range.

This machine enhances productivity by incorporation of an Auto-Cycle Tool Module and Quick Lock Collet Closure.

The Auto-Cycle Tool Module incorporates a cam cycle tool bit feed mechanism which automatically returns the tool bit to the home position ready to start the next cut.

The tool module also allows setting the start and finish cut position to minimize the cycle time.

The feed increment per revolution is adjustable to match the cutting relative to the material.

A variable speed motor provides cutting speed control for tool bit life and ID burr condition.

The Quick Lock Collet Closure mechanism actuates the collet with a single lever stroke and provides for simple collet changes.

Tool bit options are available to minimize the burr on either the mounting side or the drop-off side of the sever line and in different edge widths to match the tube wall thicknesses.

The Model 576AC also incorporates mounting features to allow use of an SQM-2AC Tube Squaring Module for optimum burr free ends.

The Model 576AC SEVERMASTER™ System, consists of the mainframe with the Quick Lock Collet Closure, Auto-Cycle Tool Module with adjustable depth of feed from .001" to .005" (.02mm to .13mm) per revolution, drive motor, wrench kit and operator's manual.

SPECIFICATIONS

WEIGHT

93 lbs (42.2 kg)

MOUNTING

Manually actuated collet clamping system.

DRIVE SYSTEMS

Pneumatic

Available on request.

Electric

115 vac, 20 to 60 hz, 11.0 amp
220 vac, 50/60 hz

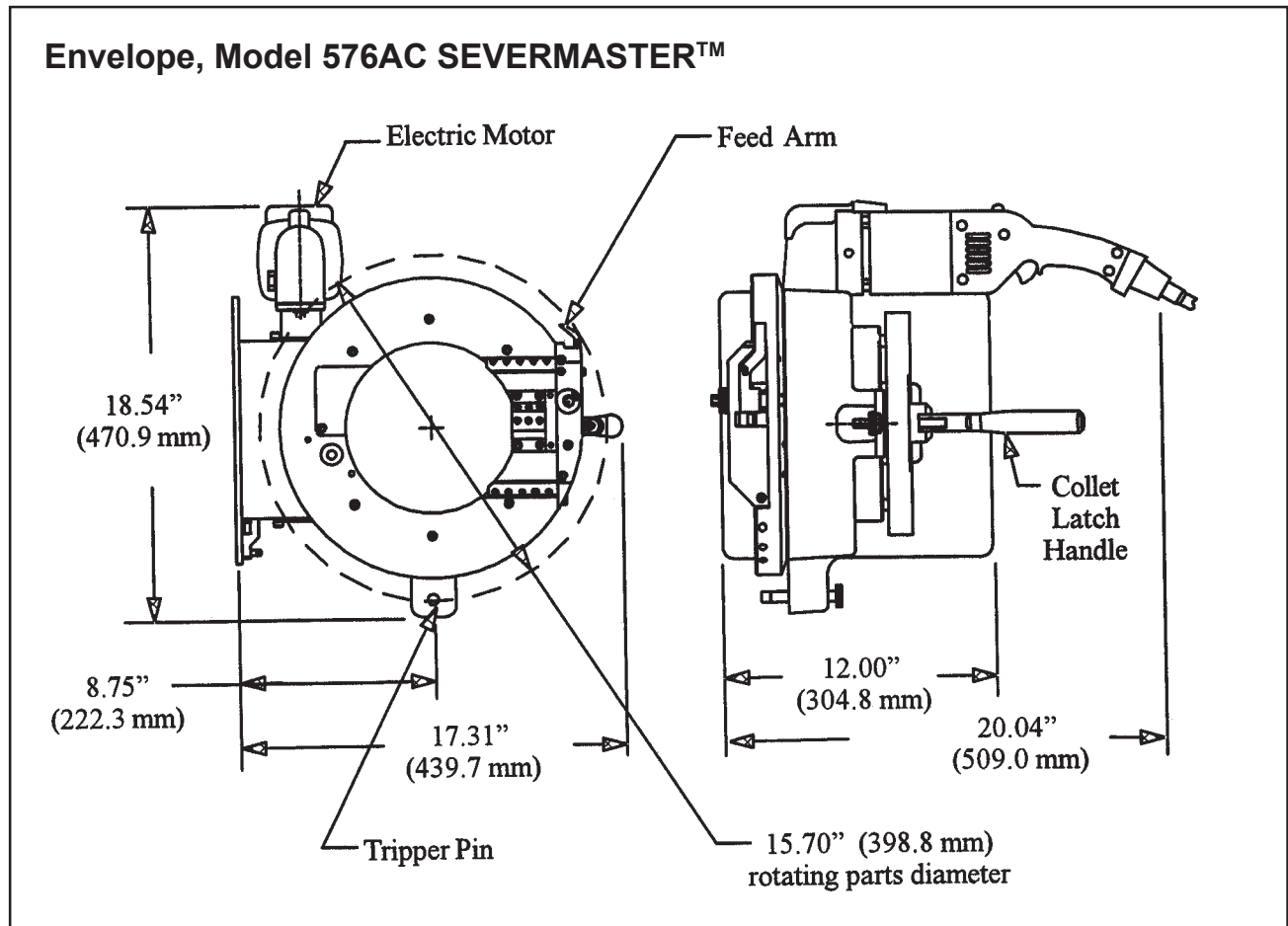

SPEED

Maximum cutting head free speed: (Electric) 40 rpm

FEED

Autofeed system adjustable from .001" (.02 mm) to .005" (.13 mm).

DESIGN AND OPERATING FEATURES

The Model 576AC accepts its own torque through the collet clamping system.

The collet provides accurate centering and full diameter support for minimum distortion of thin wall tubing.

Gear driven powerhead rotates on a precision ball bearing system.

Single lever actuation of collet.

Gears are enclosed for operator safety.

The wrenches that are required for operation of the machine are supplied.

CUTTING CAPACITIES

Pipe Sizes

2" pipe - schedules 5 and 40.

2 1/2" through 6" pipe - schedules 5 and 10.

Tube Sizes

2.00" (50.8 mm) through 6.63" (168.3 mm) DIA. tubing.

Wall Thickness Capacity

Up to .156" (4.0 mm) wall.

MAINTENANCE

All components should be cleaned and coated with a light film of oil prior to use. Use a clean, non-detergent oil, preferably SAE 10 (90 SSU) or lighter.

The air supply for the Model 576AC (pneumatic drive) should include an adequate filter, regulator and lubricator (FRL).

If the Model 576AC is operated in such a manner that the tool holder collect debris while cutting, the tool holder and the slides should be cleaned after each cutting operation.

Tool life may be severely shortened, unless chips and/or other debris that have been deposited on the cutting head during the machining operation are removed.

RECOMMENDED MAINTENANCE SCHEDULE

Daily

Wipe the unit down and spraying with rust preventative under severe humidity conditions.

Visually inspect for loose screws, missing screws, damage, etc.

Every 20 hours

Lubricate the male and female tool holder slides.

Every 40 hours

Thoroughly clean and lubricate main gear, drive gear, male and female tool slides, and tripper bracket assembly.

STORAGE

When the Model 576AC is to be stored or if it will remain out of service for a significant period of time (30 days or more), it should be thoroughly cleaned, lubricated and sprayed with a rust preventative prior to storage.

TOOL HOLDER

Clean the slide rails, the tool holder, and the feed components.

Inspect these parts for damage and replace as required.

Lubricate and reassemble.

Adjust the adjustable slide rail to provide a firm, but not excessive pressure on the tool holder.

The slide rails must be overtightened to squeeze the oil into a thin film against the male and female surfaces of the slide rails.

Reset for proper operation.

TRIPPER BRACKET ASSEMBLY LUBRICATION AND ADJUSTMENT

Back off the half-dog setscrew until it disengages from the tripper shaft.

Remove the tripper shaft assembly from the bracket and clean off all of the old lubrication.

Apply fresh lubrication to the tripper shaft assembly and reinstall it in the bracket.

Screw in the half-dog setscrew until it locates itself in the slot on the tripper shaft.

Try turning the tripper shaft assembly to insure that the setscrew is in the slot of the tripper shaft assembly and is preventing it from rotating.

LUBRICANT RECOMMENDATIONS

The drive gears require a heavy duty grease such as “Chevron Ultra Duty Grease, EP, NLG12”.

The slide rails and tool holder require a light oil such as SAE 10 light machine oil.

The tripper bracket assembly also requires a SAE 10 light machine oil for normal conditions and under dusty conditions a silicone, graphite or molybdenum disulfide ‘dry’ lubricant.

A light film of all-purpose grease may be used, but it must be checked for grit contamination frequently.

OPERATION

Read the operating instructions carefully before attempting to operate the Model 576AC SEVERMASTER™.

INSERTING THE COLLET

Select the desired size collet for the pipe or tube to be worked on.

Raise the handle to release pressure on the adjust nut.

Rotate the adjust nut until the eyebolt can be raised out of the slot and then the hinge bracket may be rotated back and down.

Remove the pusher sleeve from the main housing.

Remove the collet, if there is one, from the inside of the main housing.

Insert the correct collet into the main housing and then slide the pusher sleeve back into the main housing and into contact with the collet.

Rotate the hinge bracket back up and let the eyebolt drop back into the slot.

Rotate the adjust nut on the eyebolt to secure in the slot.

MOUNTING THE TOOL HOLDER

Select the tool holder which will allow the tool bit to reach the work surface.

Place the tool holder in the tool holder slot.

Insert the (4) four cap screws that hold the tool holder in place.

Mount tool holder #1 for tube ranging from 4.50" (114.3 mm) to 6.625" (168.3 mm).

Mount tool holder #2 for tube ranging from 2.00" (50.8 mm) to 4.50" (114.3 mm).

MACHINING INSTRUCTIONS

Turn the motor on to full speed by depressing the lever.

Engage the feed by pushing the tripper shaft in.

Monitor the cutting operation and apply cutting fluid as necessary.

The machine operation is finished when the tool holder returns home, release the lever in order to turn off the motor.

Loosen the collet by rotating the handle up.

Remove the pipe or tubing from the Model 576AC.

The tool holder will retract automatically in 5 to 10 revolutions.

There is an audible 'snap' when the tool holder returns to the home position.

Observe the relationship between the pipe or tube and the tool bit.

NOTE:

The tool holder may be reset quickly by hand by rotating the cam feed knob to pick up the feed slack.

NOTE:

It is not necessary to disengage the tripper shaft after each cutting operation.



CUTTING SPEEDS AND FEEDS

The table below shows RPM required to obtain a specified Tool Bit cutting speed on the surface of a pipe or tube.

Tube Size		Cutting Speeds Approximately		
		RPM for 200 in/min (5080 mm/min)	RPM for 250 in/min (6350 mm/min)	RPM for 300 in/min (7620 mm/min)
2"	50.8 mm	32	40	48
3"	76.2 mm	21	26	32
4"	101.6 mm	16	20	24
5"	127.0 mm	13	16	19
6"	152.4 mm	11	13	16

Use 200 surface inches per minute (5080 surface millimeters per minute) for stainless steels in general when no coolant is allowed, all heavy wall tube, and some chrome/molybdenum alloys.

Use 250 surface inches per minute (6350 surface millimeters per minute) for mild steel and some thin wall stainless steel when coolant are permitted and used.

Use 300 surface inches per minute (7620 surface millimeters per minute) for aluminum and thin-wall mild steel tube with coolant.

CUTTING FEEDS

Use very light feed for initial severing or until a continuous cut is established.

Use a feed rate .002" (.05 mm) to .003" (.08 mm) per revolution once a continuous cut is established.

If the feed is too light, only light stringer chips will be removed.

If the feed is too heavy, the drive will start to overload and the chip will take on a rough or torn appearance.

Stainless steel, which work hardens, must be worked with a heavy enough feed to stay under the work hardened surface.

Feed at rate of at least .003" (.08 mm) to .005" (.13 mm) per revolution.

Never allow the bit to burnish the surface.

Reducing cutting feed and speed will normally minimize any chatter problems.

MATERIAL CUTTING CAPABILITIES

Mild steels, chrome steels (Rc 35 max.), stainless steel, copper-nickel and aluminum without limitations other than size and wall thickness as specified.

Inconel and some other high-temperature alloys may require special procedures as a function of wall thickness. Contact TRI TOOL INC's Engineering Department for details.

COLLETS

NOTE: The size of the collet is determined by the outside diameter of the tube or pipe to be severed or squared.

Decimal Inches	mm Equivalent	Part Number
2.000	50.8	30-2558
2.008	51.0	30-2559
2.063	52.4	30-2560
2.125	54.0	30-2561
2.188	55.6	30-2562
2.240	56.9	30-2563
2.244	57.0	30-2564
2.250	57.2	30-2565
2.313	58.8	30-2566
2.375	60.3	30-2567
2.382	60.5	30-2568
2.438	61.9	30-2569
2.480	63.0	30-2570
2.492	63.3	30-2572
2.500	63.5	30-2573
2.563	65.1	30-2574
2.625	66.7	30-2575
2.688	68.3	30-2576
2.750	69.9	30-2577
2.795	71.0	30-2578
2.813	71.5	30-2579
2.875	73.0	30-2580
2.938	74.6	30-2581
2.992	76.0	30-2582
2.996	76.1	30-2583
3.000	76.2	30-2584

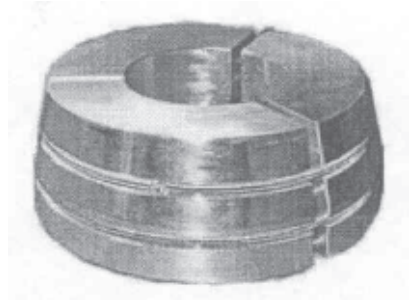

Decimal Inches	mm Equivalent	Part Number
3.004	76.3	30-2585
3.125	79.4	30-2586
3.250	82.6	30-2587
3.375	85.7	30-2588
3.500	88.9	30-2589
3.508	89.1	30-2590
3.625	92.1	30-2591
3.750	95.3	30-2592
3.875	98.4	30-2593
3.988	101.3	30-2594
4.000	101.6	30-2595
4.125	104.8	30-2596
4.250	108.0	30-2597
4.375	111.1	30-2598
4.500	114.3	30-2599
4.750	120.7	30-2600
5.000	127.0	30-2601
5.250	133.4	30-2602
5.500	139.7	30-2603
5.563	141.3	30-2604

Collets, Continued

Decimal Inches	mm Equivalent	Part Number
5.750	146.1	30-2605
6.000	152.4	30-2606
6.250	158.8	30-2607
6.500	165.1	30-2608
6.625	168.3	30-2609

Spare Parts For The Collets	
Part No.	Description
40-0238	Spring, Extension .25" dia x 12.00"
40-0248	Spring, Compression .25" dia x 1.38"
40-0249	Spring, Extension .25" dia x 1.88"
40-0250	Spring, Extension .25" dia x 6.00"

TOOL BITS

The following Tool Bits leave the burr on the piece on which the machine is mounted on:

Max. Wall Thk.	Part No.	Description
.016" thru .040"	99-5482	Tool Bit, Sever, Right Hand, .040" wide
.040" thru .065"	99-5477	Tool Bit, Sever, Right Hand, .060" wide
.065" thru .156"	99-5472	Tool Bit, Sever, Right Hand, .100" wide

The following Tool Bits leave the burr on the piece opposite to which the machine is mounted on:

Max. Wall Thk.	Part No.	Description
.016" thru .040"	99-5481	Tool Bit, Sever, Right Hand, .040" wide
.040" thru .065"	99-5480	Tool Bit, Sever, Right Hand, .060" wide
.065" thru .156"	99-5473	Tool Bit, Sever, Right Hand, .100" wide

INSTALLATION

WARNING: Make sure that the Model 576AC is disconnected from its power source before installing a tool bit.

Install a collet into the Model 576AC.

Insert a tube into the collet and bring it flush to the front of the collet and clamp the tube in place.

Rotate the cam feed knob counter-clockwise with a 3/8" wrench, so that the scribe mark points to the bottom (this will place the tool holder to the end of the feed).

NOTE: The cam can only rotate in the direction noted on the knob with an arrow.

Slide a tool bit into the tool slot until the end of the cutting edge of the tool bit passes the ID of the tube by approximately .020".

CAUTION: DO NOT install the tool bit backwards; it will not cut and may destroy the tool bit.

Secure the tool bit in place by tightening the (6) six set screws in the tool holder.

Rotate the cam feed knob until the tool holder returns to top of its travel.

Screw in the feed limit adjustment screw until the end of the cutting edge of the tool bit just clears the OD of the tube.

Rotate the cam feed knob counter-clockwise to pick up the feed slack.

Loosen the collet and re-position the tube to sever.

To adjust the feed rate, loosen feed lock screw, rotate the feed adjustment screw and read the feed rate graduations to find the desired feed rate.

Some experimentation should be made to maximize the efficiency and tool bit life.

WARNING: A feed rate of .002" to .003" (.05 mm to .08 mm) will accommodate most tube materials.

When the desired feed rate is set, tighten the feed lock screw. (DO NOT over tighten.)

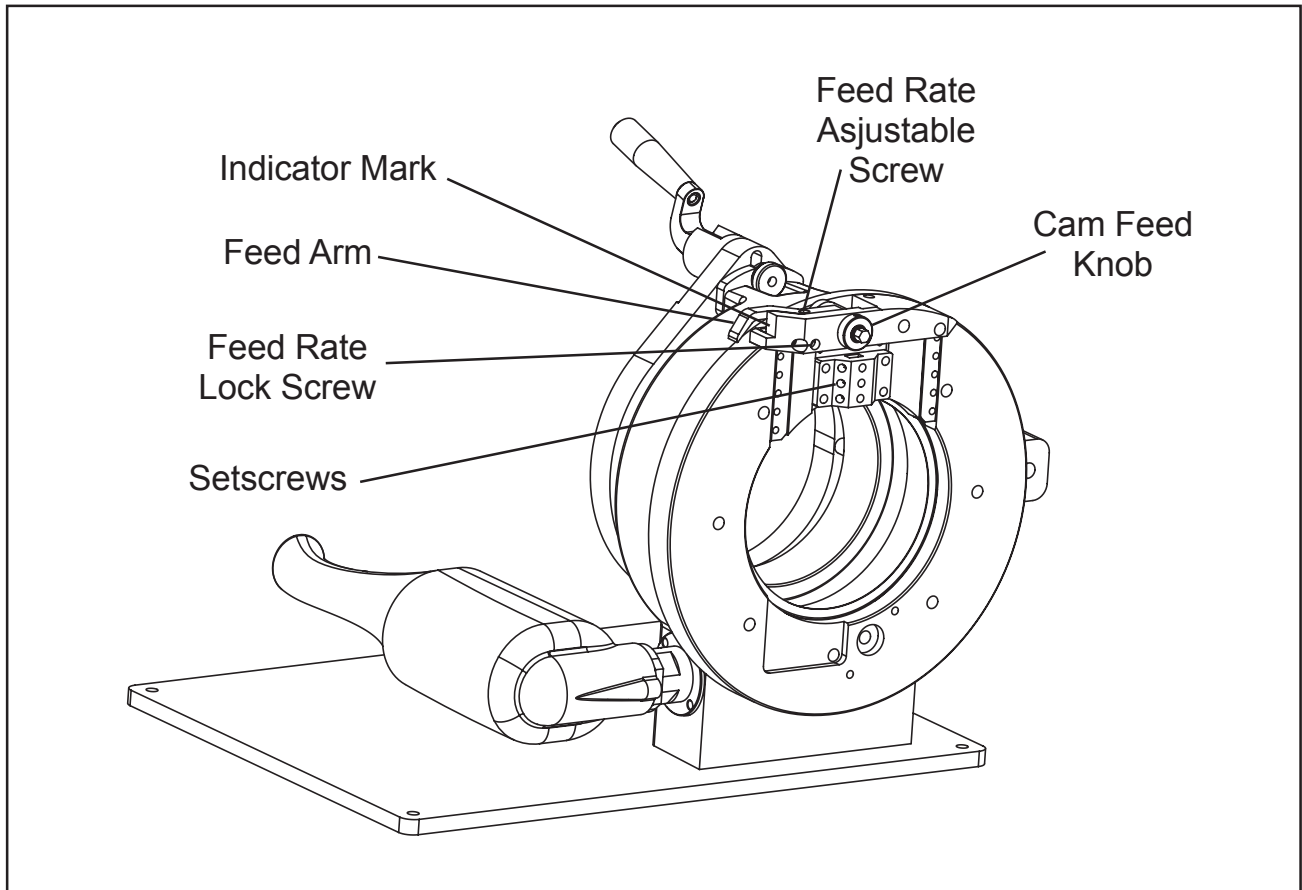

TROUBLE SHOOTING

Problem: The Tool Bit Chatters

- The tool bit is loose or overextended.
- The tool bit is damaged.
- The tool holder is too loose in the slides.
- The cutting speed is too fast.
- The clamping pads are loose on the pipe or tube.
- Cutting fluid is required.
- The main bearing pre-load is loose.

Problem: There's Excessive Tool Bit Wear

- The pipe or tube material is too hard or abrasive.
- The cutting speed is too fast.
- Cutting fluid is required.
- A dull Tool Bit is causing surface hardening conditions (Stainless pipe or tubing).
- There is scale or other foreign matter on the pipe or tube, which is dulling the tool bit at the start of the cut.
- The tool bit is incorrect for the material being cut.

Problem: The Surface Finish is Rough

- The tool bit is dull, chipped, etc.
- Metal build-up on the cutting edge of the tool bit is creating a false cutting edge.
- Cutting fluid is required.

Problem: The Tool Holder is Not Feeding

- The feed pin is broken or out of position.
- The feed sprocket shear pin is broken.
- The feed screw is stripped.
- The feed nut is stripped.
- The slide rails are too tight.

Problem: The Tool Bit is diving and the SEVERMASTER™ is stalling

The tool bit is dull, chipped, etc.
The tool holder adjustment slide is too loose.
The tool bit is over-extended

Problem: The pipe or tube is slipping in the collet

The clamping pressure is not tight enough.
Scale and/or other foreign material is present on the pipe or tube.
Weld seams, swelling, or bumps are preventing full contact of the collet.
Dull tool bits are causing extra force in the axial and/or radial direction.

Problem: There's a Loss of Air Power

The air supply pressure is too low.
The air filter is plugged.
The air line size is insufficient.
The air line is too long.

Problem: The Tool Bit Will Not Reach the Work

Incorrect tool blocks are installed for the size of the pipe or tube being worked on.
Incorrect tool bit is installed.

Problem: The Air Motor Will Not Start

The air power supply is shut off.
The air motor is damaged and will not run free.
The air motor needs lubrication.
Add lubrication and do not run the air motor for a few minutes, then try running the motor.
Tap on the side of the air motor casing lightly with a piece of wood or with a soft rubber mallet just in case the vanes may be sticking.
Sand or other foreign material may be in the vanes of the air motor.

ACCESSORIES

The following accessories are recommended for use with the Model 576AC SEVERMASTER™ and are available from TRI TOOL INC.

1. Portable Air Filter Caddy (P/N 57-0100)
2. SQM-2AC Squaring Module Kit (P/N 05-0320)
3. Extended Tool Holder #3 (P/N 49-0326*)
*Available by Special Order Only.

A portable Air Caddy (FRL) is required to protect the warranty on all TRI TOOL INC air driven tools.

ILLUSTRATED PARTS BREAKDOWN

MODEL 576AC SUB-ASSEMBLY, GROUP A (P/N 02-2226)

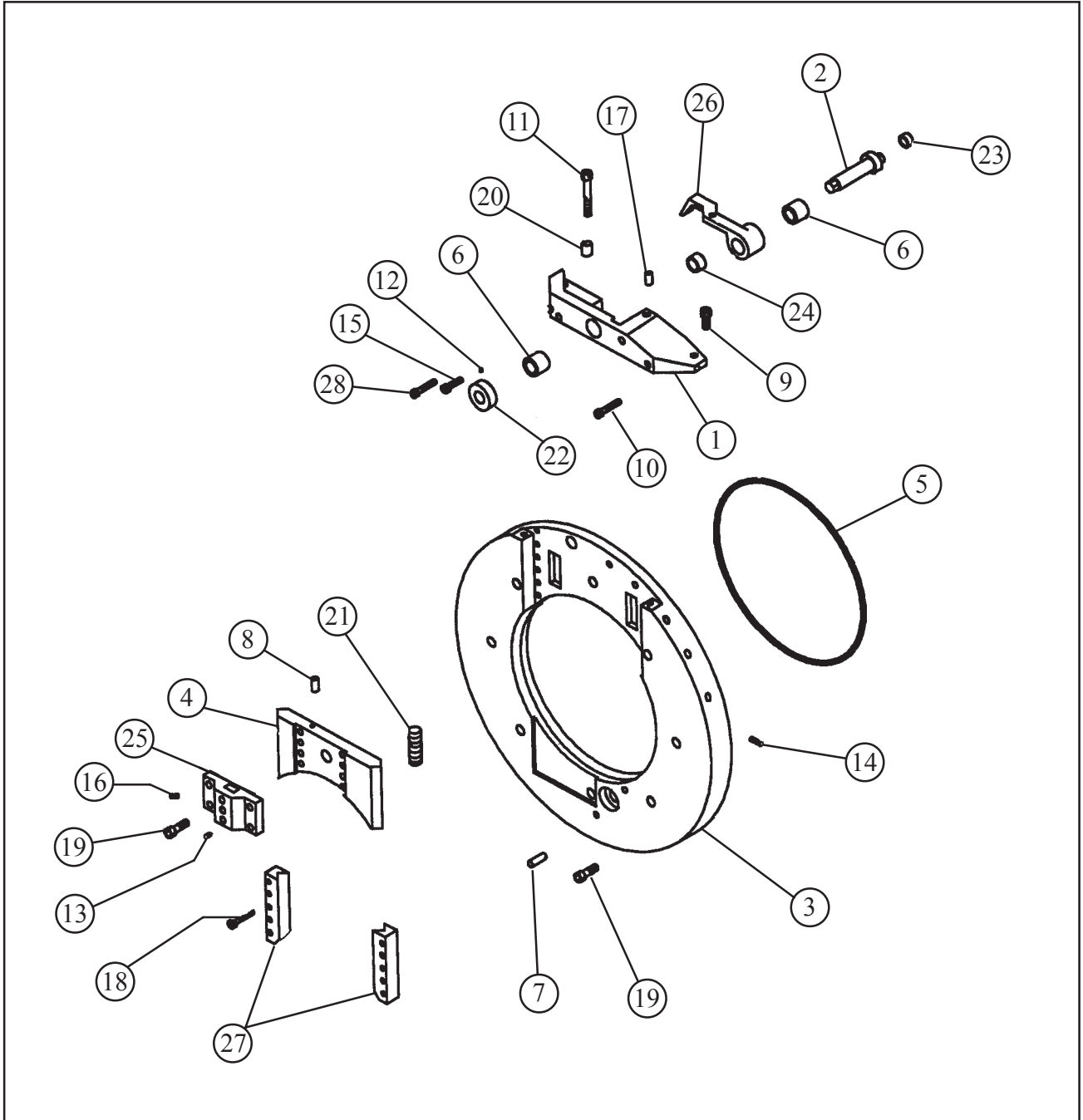

TRI TOOL INC.

Parts List, Model 576AC Sub-Assembly, Group A (P/N 02-2226)

Item No.	Part No.	Description	Qty
1.	19-0778	HOUSING, FEED	1
2.	20-0644	SHAFT, FEED, CAM	1
3.	24-1514	PLATE, MAIN	1
4.	24-1515	PLATE, TOOL	1
5.	28-0262	O-RING	1
6.	30-2490	CLUTCH, ROLLER	2
7.	32-0140	PIN, DOWEL, 1/4 DIA X 3/4"	2
8.	32-0497	PIN, STOP	1
9.	33-0039	SCREW, CAP, 1/4-20 X 5/8"	2
10.	33-0045	SCREW, CAP, 1/4-20 X 1 3/4"	2
11.	33-0203	SCREW, CAP, #10-32 X 7/8"	1
12.	33-0489	SCREW, SET, #10-24 X 5/16", CUP PT	1
13.	33-0514	SCREW, SET, 5/16-18 X 3/8", CUP PT	3
14.	33-1147	SCREW, SET, 5/16-18 X 1", HDOG	3
15.	33-1985	SCREW, CAP, # 10-32 X 1/2"	1
16.	33-1986	SCREW, SET, 5/16-18 X 1/2", CONE PT	3
17.	33-1998	SCREW, SET, 5/16-18 X 3/4" HD, LOCK	1
18.	33-2002	SCREW, CAP, #10-24 X 7/8", SS	10
19.	33-0040	SCREW, CAP, 1/4-20 X 3/4", ZP	12
20.	40-0255	SPRING, COMPRESSION	1
21.	40-0240	SPRING, COMPRESSION	2
22.	42-0171	KNOB, CAM FEED SHAFT	1
23.	45-0260	BUSHING, BRONZE	1
24.	45-0261	BUSHING, BRONZE	1
25.	49-0320	HOLDER, TOOL, #1	1
26.	63-0137	ARM, FEED	1
27.	66-0164	RAIL, SLIDE	2
28.	33-0044	SCREW, CAP, 1/4-20 X 1 1/2"	1

MODEL 576AC SUB-ASSEMBLY, GROUP B (P/N 02-2226)

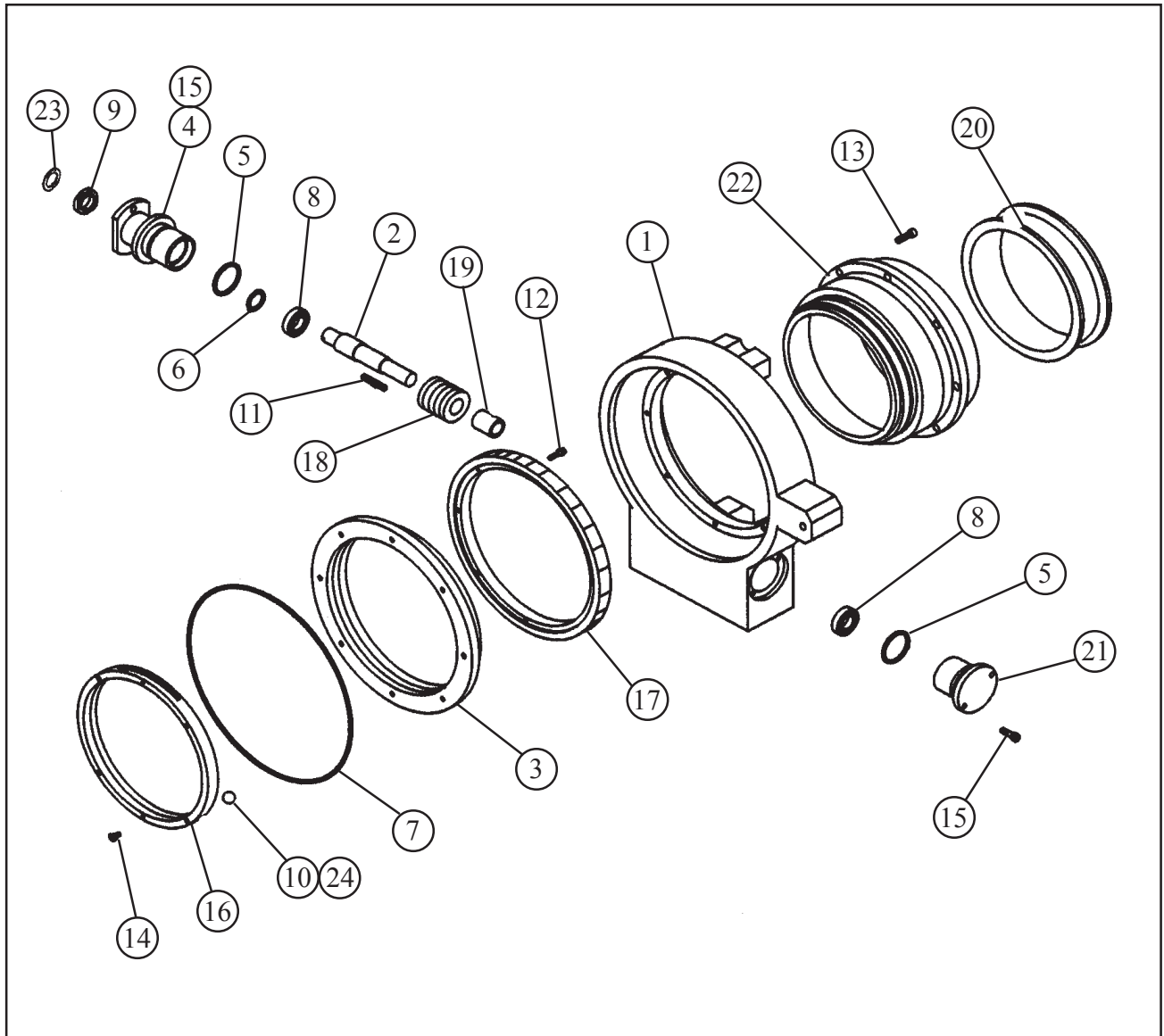

TRI TOOL INC.

Parts List, Model 576AC Sub-Assembly, Group B (P/N 02-2226)

Item No.	Part No.	Description	Qty
1.	19-0777	HOUSING, MAIN	1
2.	20-0651	SHAFT, DRIVE	1
3.	20-0652	SHAFT, MAIN	1
4.	27-0575	ADAPTOR, MOTOR	1
5.	28-0264	O-RING	2
6.	28-0245	SEAL, GREASE	1
7.	28-0263	O-RING	1
8.	29-0020	BEARING, BALL	2
9.	29-0096	BEARING, BALL	1
10.	30-2612	BEARING, BALL, STEEL, 3/8" DIA	40
11.	31-0142	KEY	1
12.	33-0030	SCREW, CAP, #10-24 X 3/4", ZP	8
13.	33-0041	SCREW, CAP, 1/4-20 X 7/8", ZP	8
14.	54-0398	PLUG, PRESSURE	4
15.	33-0040	SCREW, CAP, 1/4-20 X 3/4", ZP	4
16.	35-0534	NUT, ADJUSTMENT, BEARING RACE	1
17.	39-0815	GEAR, MAIN, WORM	1
18.	39-0819	GEAR, WORM	1
19.	44-0473	SPACER	1
20.	44-0474	SPACER, COLLET	1
21.	46-0446	SLEEVE, END	1
22.	46-0448	SLEEVE, MAIN INNER	1
23.	40-0271	SPRING, WAVE DISC	1
24.	30-2707	BALL, TEFLON 5/16" DIA.	40
NOT SHOWN			
	29-0362	BERAING, INNER RACE	REF
	46-0467	SLEEVE, MAIN INNER RACE	REF

MODEL 576AC SUB-ASSEMBLY, GROUP C (P/N 02-2226)

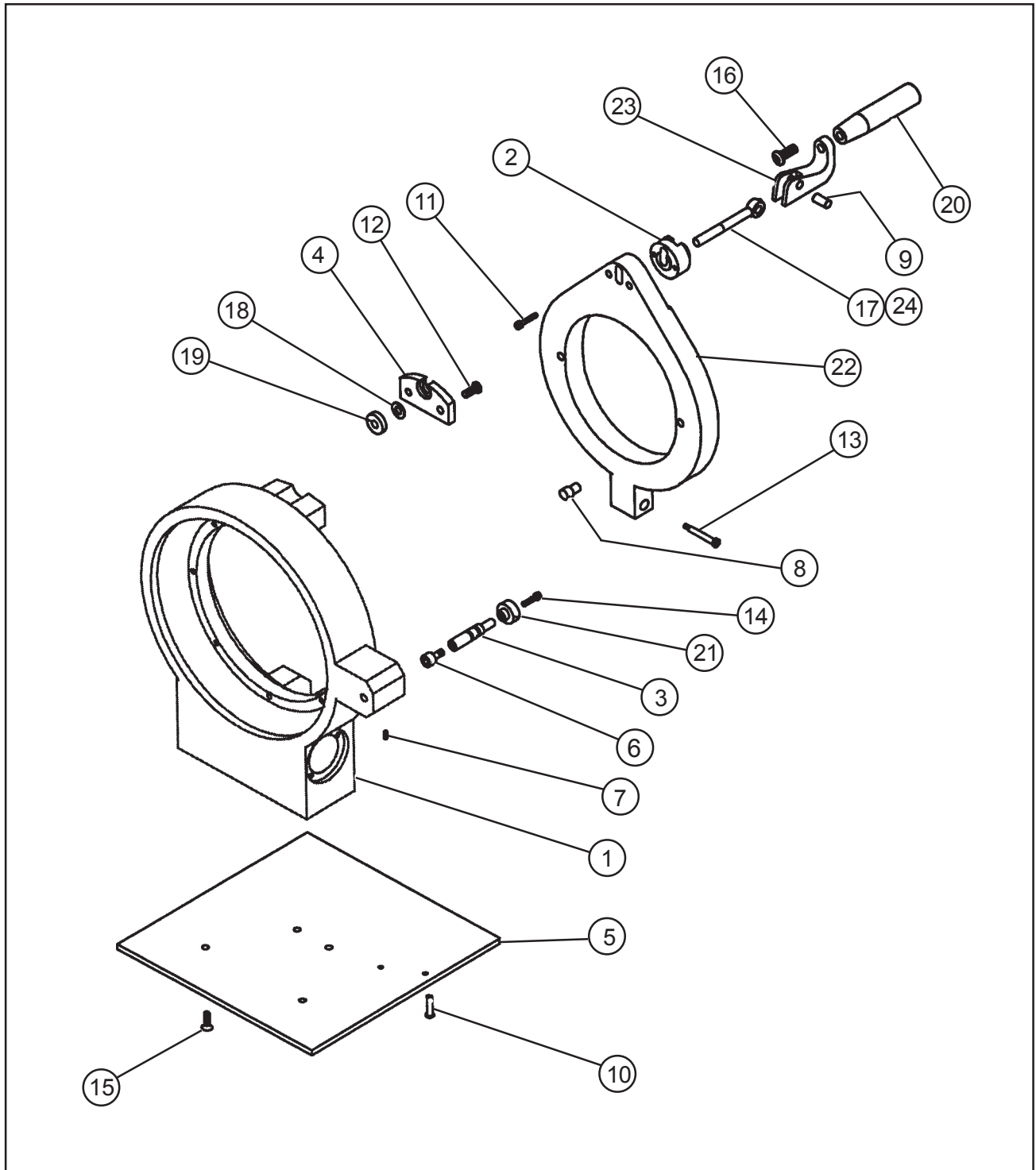

TRI TOOL INC.

Parts List, Model 576AC Sub-Assembly, Group C (P/N 02-2226)

Item No.	Part No.	Description	Qty
1.	19-0777	HOUSING, MAIN	REF
2.	20-0633	SHAFT, CLAMP	1
3.	20-0637	SHAFT, TRIPPER	1
4.	24-1511	PLATE, CLAMP	1
5.	24-1525	PLATE, STAND	1
6.	29-0031	CAM FOLLOWER	1
7.	30-0125	PLUNGER, BALL, 1/4-20 X 17/32"	1
8.	30-2611	BUTTON, SPHERICAL	2
9.	32-0260	PIN, DOWEL, 3/8 DIA X 3/4"	1
10.	32-0509	PIN, CLEVIS, 1/4"	2
11.	33-0032	SCREW, CAP, #10-24 X 1"	2
12.	33-0300	SCREW, BUTTON HEAD, 3/8-16 X 1"	2
13.	33-1950	SCREW, SHOULDER, 1/2" DIA X 2 1/2"	1
14.	33-2001	SCREW, CAP, SS, #10-24 X 3/4"	1
15.	33-2005	SCREW, FLAT HEAD, SS, 5/16-18 X 3/4", SS	4
16.	33-2006	SCREW, BUTTON HEAD, SS, 3/8-16 X 1"	1
17.	33-2075	EYEBOLT	1
18.	34-0134	SELF ALIGN, WASHER SET, 3/8"	1
19.	35-0139	NUT, CHECK , 3/8-16 X 7/16"	1
20.	41-0125	HANDLE	1
21.	42-0023	KNOB	1
22.	47-1163	BRACKET, HINGE	1
23.	62-0110	CAM, CLAMP	1
24.	33-0619	SCREW, CAP, 10-32 X 1/4", CUP PT	1
NOT SHOWN			
	05-1319	WRENCH KIT	
	36-0007	WRENCH, L, 5/32" HEX	1
	36-0008	WRENCH, L, 3/16" HEX	1
	36-0020	WRENCH, T, 5/32" HEX	1
	36-0052	WRENCH, COMBINATION, 3/8"	1
	49-0321	HOLDER, TOOL #2	1

ELECTRIC MOTOR ASSEMBLY (P/N 58-0112)

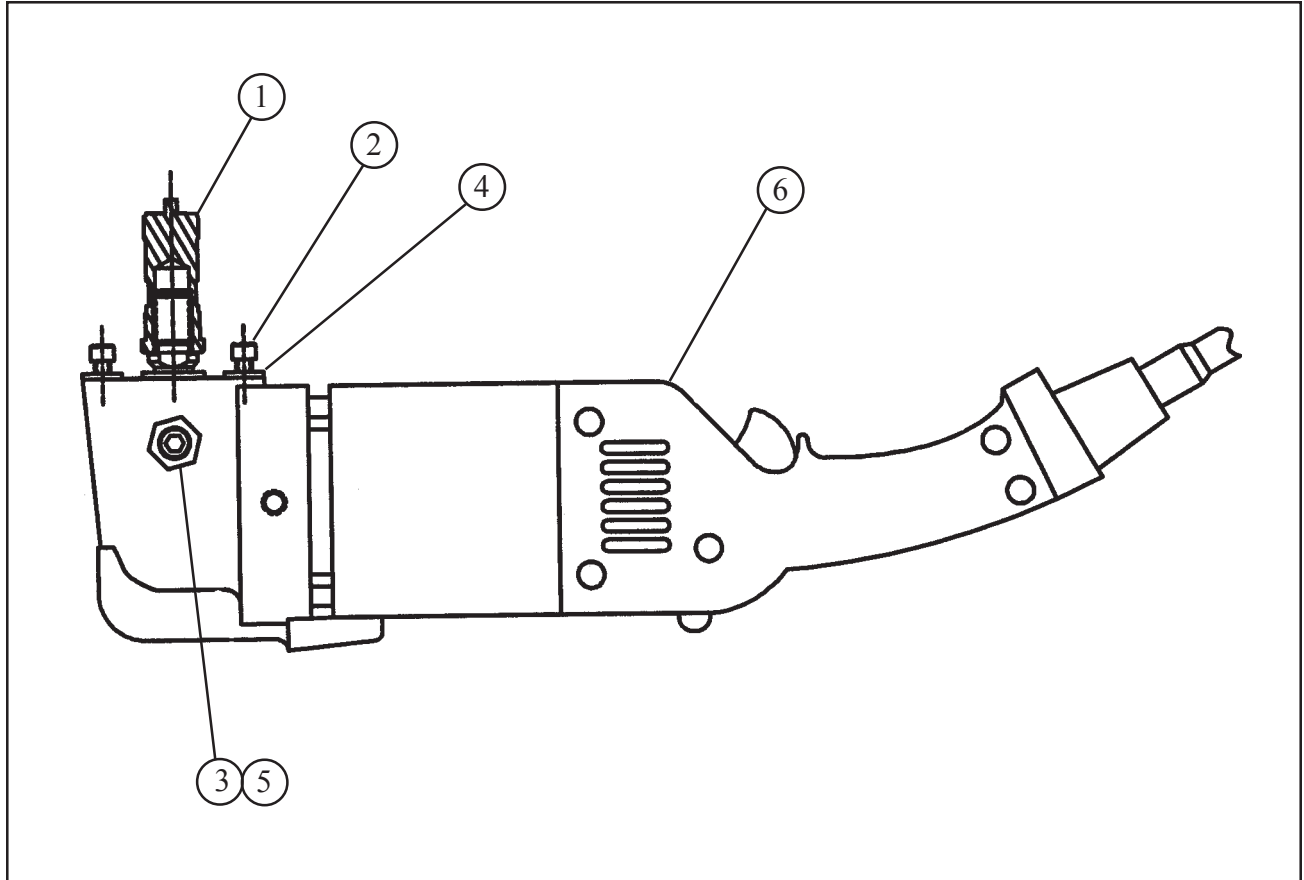

Parts List, Electric Motor Assembly (P/N 58-0112)

Item No.	Part No.	Description	Qty
1.	27-0576	ADAPTER, DRIVE	1
2.	33-0041	SCREW, CAP, 1/4-20 X 7/8", ZP	2
3.	33-0660	SCREW, SET, CUP PT, 1/2-20 X 1/2"	2
4.	34-0026	WASHER	2
5.	35-0117	NUT, JAM, 1/2-20 X 5/16	1
6.	58-0111	MOTOR, ELECTRIC, 110 VAC	1