

MODEL 8-4000

ILLUSTRATED PARTS BREAKDOWN MANUAL

MODEL 8-4000
IPB Notice and Revision History



This document and the information contained herein is the property of Arc Machines, Inc. It is proprietary and submitted and received in confidence. It shall be used only for the purpose for which it is submitted and shall not be copied in whole or in part without the prior express written permission of Arc Machines, Inc. The information in this document has been carefully reviewed and is believed to be accurate. However, no responsibility is assumed for inaccuracies. Information and part numbers in this document are subject to change and Arc Machines, Inc. reserves the right to change required data without notice.



WARNING

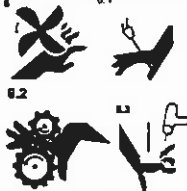

The nature of the GTAW process creates some POTENTIAL HAZARDS. In accordance with international safety regulations the EXCLAMATION SYMBOL indicates that this equipment is considered HAZARDOUS. The LIGHTNING FLASH SYMBOL indicates that there are potential electrical hazards. The display of these symbols makes it the OPERATOR'S RESPONSIBILITY TO ENSURE THAT THEY HAVE BEEN MADE AWARE OF and shall observe the hazardous conditions.

	WARNING: AMI factory training is essential for all Maintenance Technicians who operate AMI equipment. Do not operate or service this equipment without proper AMI approved training.
	WARNING: Keep hands and fingers clear from moving parts such as fans, gears, rotors, Wire Feed, Weld Head Travel, i.e. Oscillation (OSC) and Arc Voltage Control (AVC) mechanisms Weld Head AVC and Oscillator Slide Assemblies develop high forces and it is possible, by their nature of operation, to harm any object or body part that may get into these areas. USE EXTREME CAUTION!
	Electrical Shock Hazard: Always disconnect weld heads when servicing internal components or opening housing covers for access.

All rights reserved.
Publication date: First Edition – June 5, 2007
Copyright 2007 by Arc Machines, Inc.

REV	ECO #	CHANGE DESCRIPTION	DATE	BY	APR
A	4779	Added 750015 rev D	28 May 2008	SO	BF
B	5011	In IPB 080803, changed Item 3 to SCS02-56-0,25NP was SBS02-56-0,25NP	26 Jun 2008	SO	BF
C	5467	In IPB 080103 changed item 10 to 13080733-02 was 22080730-01.	9 Dec 2009	LK	WO
D	5579	Added rev F of 750015 and Wiring Diagram	18 Jan 2010	CB	DC

TABLE OF CONTENTS

DATE EFFECTIVE: 16 OCT 1996

PRODUCT MODEL: 8-4000
MANUAL NUMBER: 730095

IPB NUMBER	DESCRIPTION
750015	ELECTRODE DIMENSIONS
080100	WELD HEAD TOP ASSEMBLY
080101	WELD HEAD BASIC ASSEMBLY
080103	HOUSING HSG SIDE ASSEMBLY
080102	HOUSING COVER SIDE ASSEMBLY
080803	LIMIT SWITCH-TRIM POT ASSEMBLY
080601	MOTOR DRIVE ASSEMBLY
080700	ROTOR ASSEMBLY
080800	CABLE ASSEMBLY
47081702	MODEL 8-4000 WIRING DIAG

ELECTRODE DIMENSIONS

ROTOR DIAMETER	
MODEL NO.	ROTOR O.D.
9-250	0.802
9-500/4-500	1.388
9-675	1.715
9M-750	1.312
9-750	2.000
9-1500	3.187
9AF-1500	2.252
9E-1500	2.687
8-2000	3.450
9-2500	4.380
9AF-2500	3.156
9E-2500	4.280
* 9-3500	5.380
9E-3500	5.310
8-4000	5.310
* 9-4500	6.875
9ER-4500	5.776
8-6625	8.094
* 9-7500	10.440
9E-7500	9.375
* FOR HEADS USING OPTIONAL TUNGSTEN EXTENDER, SEE PAGE 2.	

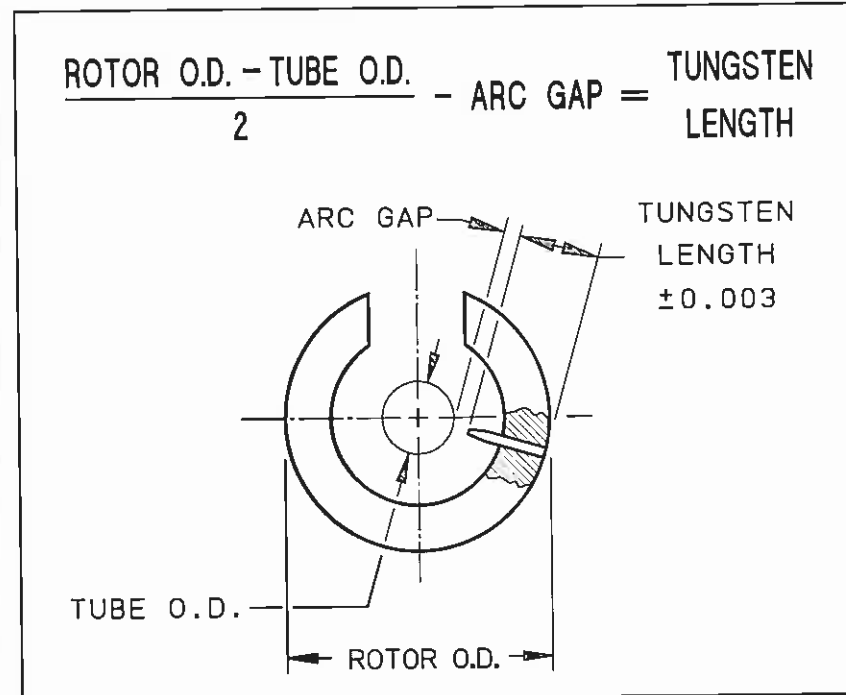

TUBE/PIPE WALL THICKNESS	RECOMMENDED ARC GAP	RECOMMENDED TIP DIA.
0.020/0.035	0.030	0.020
0.049/0.085	0.050	0.030
0.091/0.154	0.070	0.040

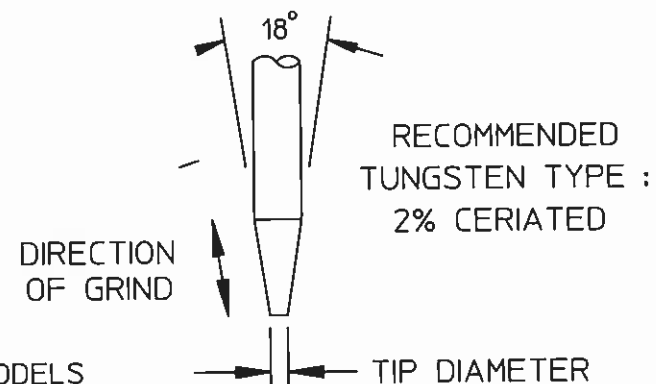

- NOTES:
1. RECOMMENDED ARC GAP FOR MODELS 4-500, 9-250 & 9-500 IS 0.045 MAXIMUM.
 2. IN INSTANCES WHERE OUT-OF-ROUNDNESS ON THIN-WALLED TUBING OCCURS (NORMALLY 2.500 O.D. OR LARGER), A 0.070 ARC GAP IS RECOMMENDED.
 3. DIMENSIONS ARE IN INCHES.

TUNGSTEN LENGTH CALCULATION FOR TUNGSTEN EXTENDERS

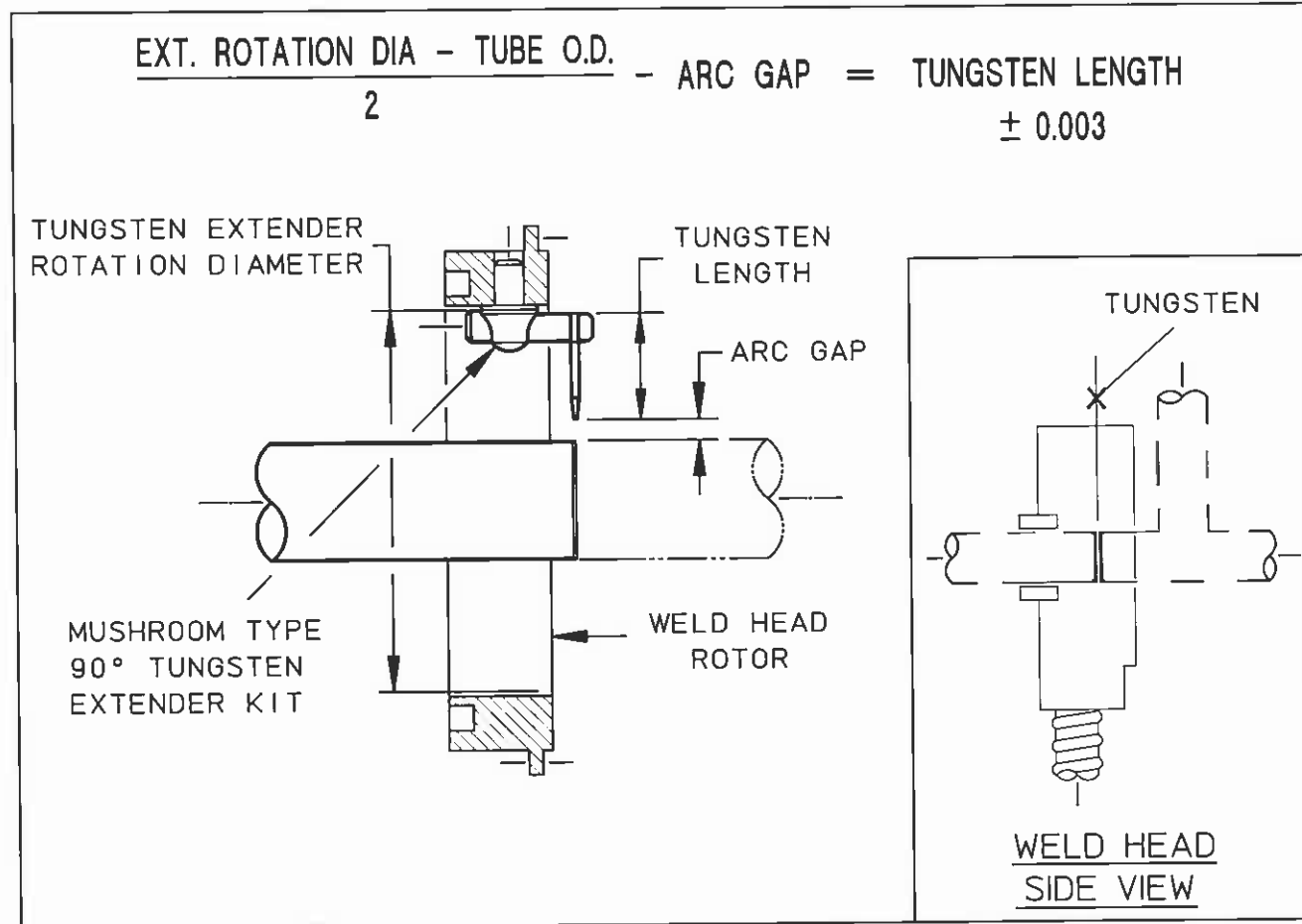

WELD HEAD MODEL NO.	KIT WITH 1/16 TUNGSTEN HOLDER PART NO.	KIT WITH 3/32 TUNGSTEN HOLDER PART NO.	TUNGSTEN EXTENDER ROTATION DIA.
9-1500	13090796-01	13090796-02	2.031
9-2500	13090796-05	13090796-06	3.156
9-3500	13090796-05	13090796-06	4.031
9-4500	13090796-03	13090796-04	4.920
9-7500	13090796-05	13090796-06	8.280

NOTES:

1. PART NUMBERS SHOWN ARE FOR REFERENCE ONLY AND ARE SUBJECT TO CHANGE.
2. CONTACT AMI SALES OR SERVICES FOR SPECIFIC PART NUMBER.

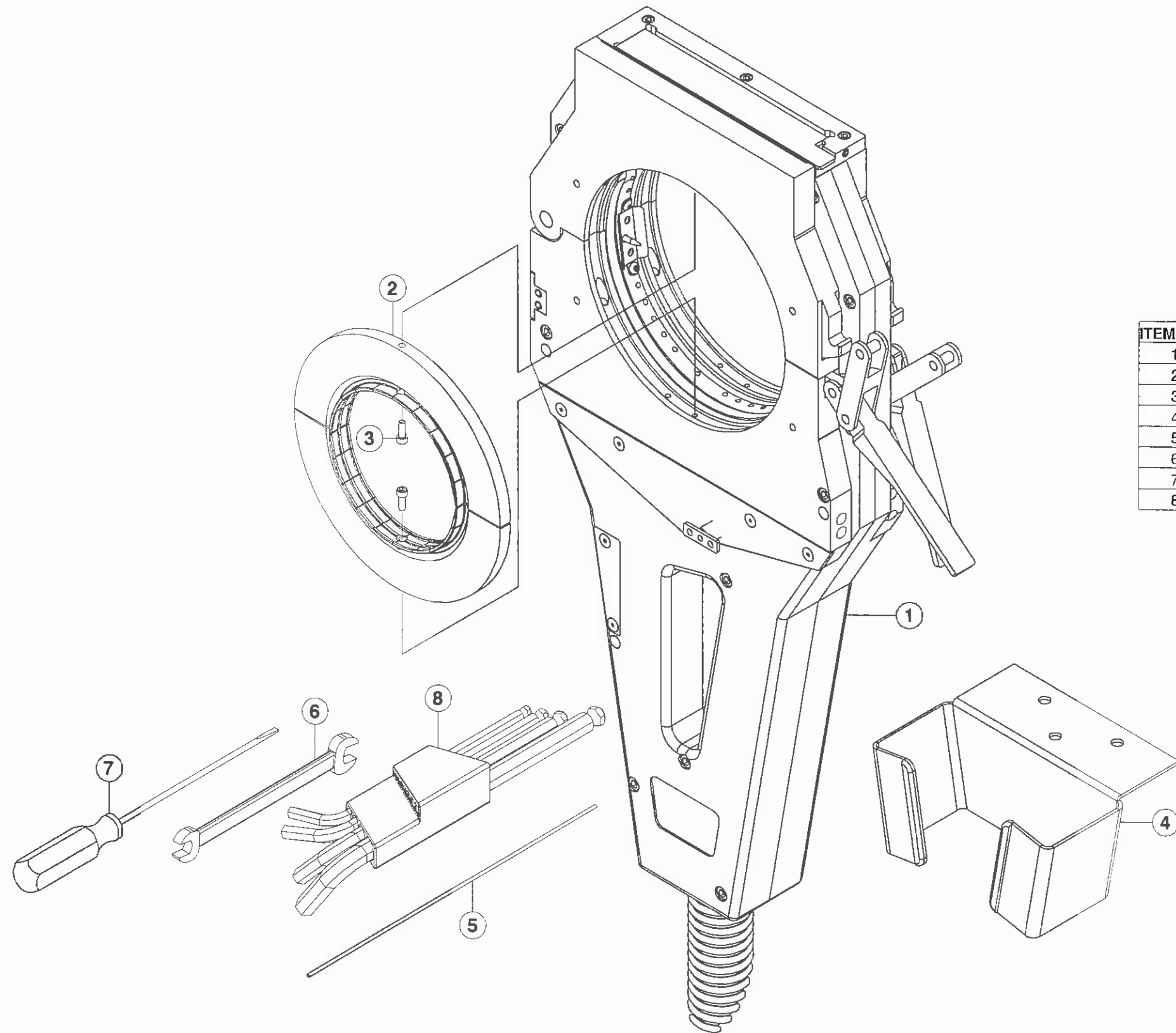

ITEM NO.	QTY.	PART NO.	DESCRIPTION
1	1	13080101-01	WELD HEAD BASIC ASSY
2	1	14080506-01	LIST SELECT INSERT
3	2	SCS04-40-0,31NP	SCREW CAP SKT 4-40 5/16 L
4	1	42080102-01	BRACKET BENCH MOUNT (OPTION)
5	1	TC06	TUNG 2% CERIA .062 DIA 7.00L
6	1	21004	WRENCH OPEN-END 1/4 X 5/16
7	1	R3324	SCREWDRIVER SLOTTED 3/32 X 4IN LONG
8	1	BLX-12	WRENCH L HEX BALL DRIVE SET 12 PIECE

MODEL 8-4000
IPB 080100
WELD HEAD TOP ASSEMBLY

ISSUED: 16 OCT 1996
REVISED: 7 JUL 2004

THIS DOCUMENT OR DRAWING AND THE INFORMATION CONTAINED HEREIN IS THE PROPERTY OF ARC MACHINES, INC., IS PROPRIETARY, IS SUBMITTED AND RECEIVED IN CONFIDENCE. SHALL BE USED ONLY FOR THE PURPOSE FOR WHICH IT IS SUBMITTED AND SHALL NOT BE COPIED IN WHOLE OR IN PART WITHOUT THE PRIOR EXPRESS WRITTEN PERMISSION OF ARC MACHINES, INC.

AMI
ARC MACHINES, INC.

ITEM NO.	QTY.	PART NO.	DESCRIPTION
1	1	13080103-01	HOUSING HSG SIDE ASSY
2	1	13080102-01	HOUSING COVER SIDE ASSY
3	1	13080561-01	CLAMP HOUSING HSG SIDE ASSY
4	1	13080560-01	CLAMP HOUSING COVER SIDE ASSY
5	1	13080515-01	BRACKET COOLING ASSY
6	1	13080506-01	WINDOW ASSY
7	3	42090164-02	PIN .25OD 1.72L
8	1	42080557-01	PLATE COVER CLAMP HSG
9	1	42081103-01	COVER LIMIT SWITCH
10	4	R00109-040-40SL	O RING
11	10	SFS04-40-0,25NP	SCREW FLH SKT 4-40 1/4 L
12	3	SCS06-32-0,31NP	SCREW CAP SKT 6-32 5/16 L
13	8	SCS08-32-0,50NP	SCREW CAP SKT 8-32 1/2 L
14	2	SCS08-32-1,50SS	SCREW CAP SKT 8-32 1-1/2 L SST
15	4	SCS08-32-0,87NP	SCREW CAP SKT 8-32 7/8 L
16	2	SSS06-32-18NPCU	SCREW SET SKT 6-32 3/16 L CUPT
17	4	SCS04-40-0,31NP	SCREW CAP SKT 4-40 5/16 L
18	2	14080506-01	LIST SELECT INSERT

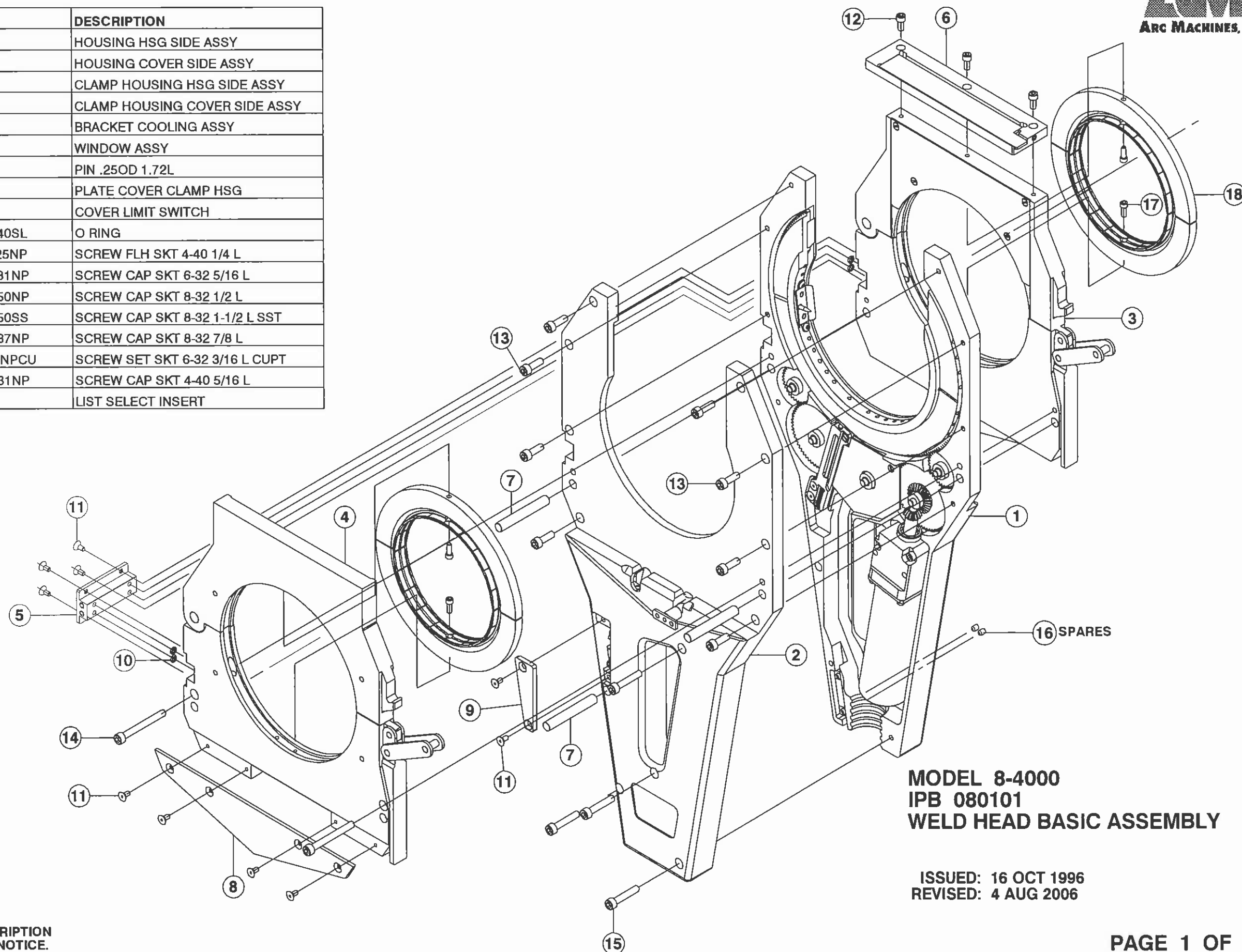

**MODEL 8-4000
IPB 080101
WELD HEAD BASIC ASSEMBLY**

ISSUED: 16 OCT 1996
REVISED: 4 AUG 2006

TO ORDER USE PART NUMBER.
PRICE, PART NUMBER AND DESCRIPTION
SUBJECT TO CHANGE WITHOUT NOTICE.

THIS DOCUMENT OR DRAWING AND THE INFORMATION CONTAINED HEREIN IS THE PROPERTY OF ARC MACHINES, INC. IS PROPRIETARY, IS SUBMITTED AND RECEIVED IN CONFIDENCE. SHALL BE USED ONLY FOR THE PURPOSE FOR WHICH IT IS SUBMITTED AND SHALL NOT BE COPIED IN WHOLE OR IN PART WITHOUT THE PRIOR EXPRESS WRITTEN PERMISSION OF ARC MACHINES, INC.



ITEM NO.	QTY.	PART NO.	DESCRIPTION
1	1	13080107-01	HOUSING HSG SIDE ASSY
2	1	13080601-01	MOTOR DRIVE ASSY
3	1	13081100-01	HOUSING LIMIT SWITCH ASSY
4	1	13080700-01	ROTOR ASSY
5	2	13080600-04	GEAR DRIVE ASSY
6	1	13080600-01	GEAR SPUR BEVEL ASSY
7	2	13080600-02	GEAR DRIVE 60 TEETH ASSY
8	1	42080601-01	COVER GEAR
9	1	42080702-01	GUIDE RING M8-4000
10	1	13080733-02	KIT HEAT SHIELD M8-4000
11	1	3057L-1-202	POT TRIM 2K 1-1/4 IN RECT MULTI TURN
12	5	SSRI6632LLRA3P25LY	BEARING BALL .18 .37 [15]
13	2	SFL04-40-0,25NY	SCREW FLH SLT 4-40 1/4 L NYL
14	2	SFS04-40-0,37NP	SCREW FLH SKT 4-40 3/8 L
15	2	SCS06-32-1,12NP	SCREW CAP SKT 6-32 1-1/8 L
16	9	SFL04-40-0,18N	SCREW FLH SLT 4-40 3/16 L NYL
17	2	SBS04-40-0,18NP	SCREW BTH SKT 4-40 3/16 L
18	2	SBS02-56-0,25NP	SCREW BTH SKT 2-56 1/4 L
19	1	ELECTRODE	(REF.)

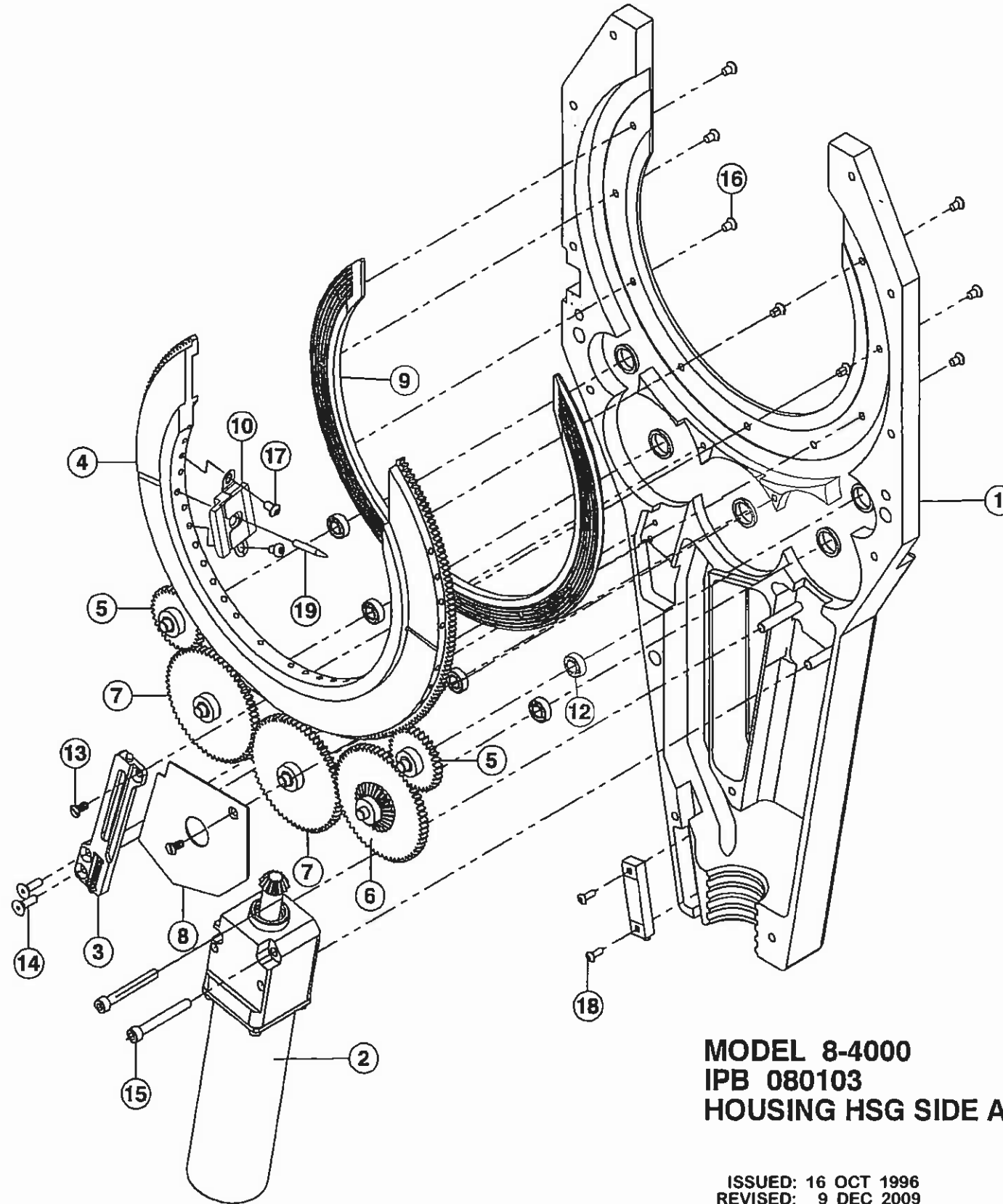

MODEL 8-4000
 IPB 080103
 HOUSING HSG SIDE ASSEMBLY

ISSUED: 16 OCT 1996
 REVISED: 9 DEC 2009

TO ORDER USE PART NUMBER.
 PRICE, PART NUMBER AND DESCRIPTION
 SUBJECT TO CHANGE WITHOUT NOTICE.

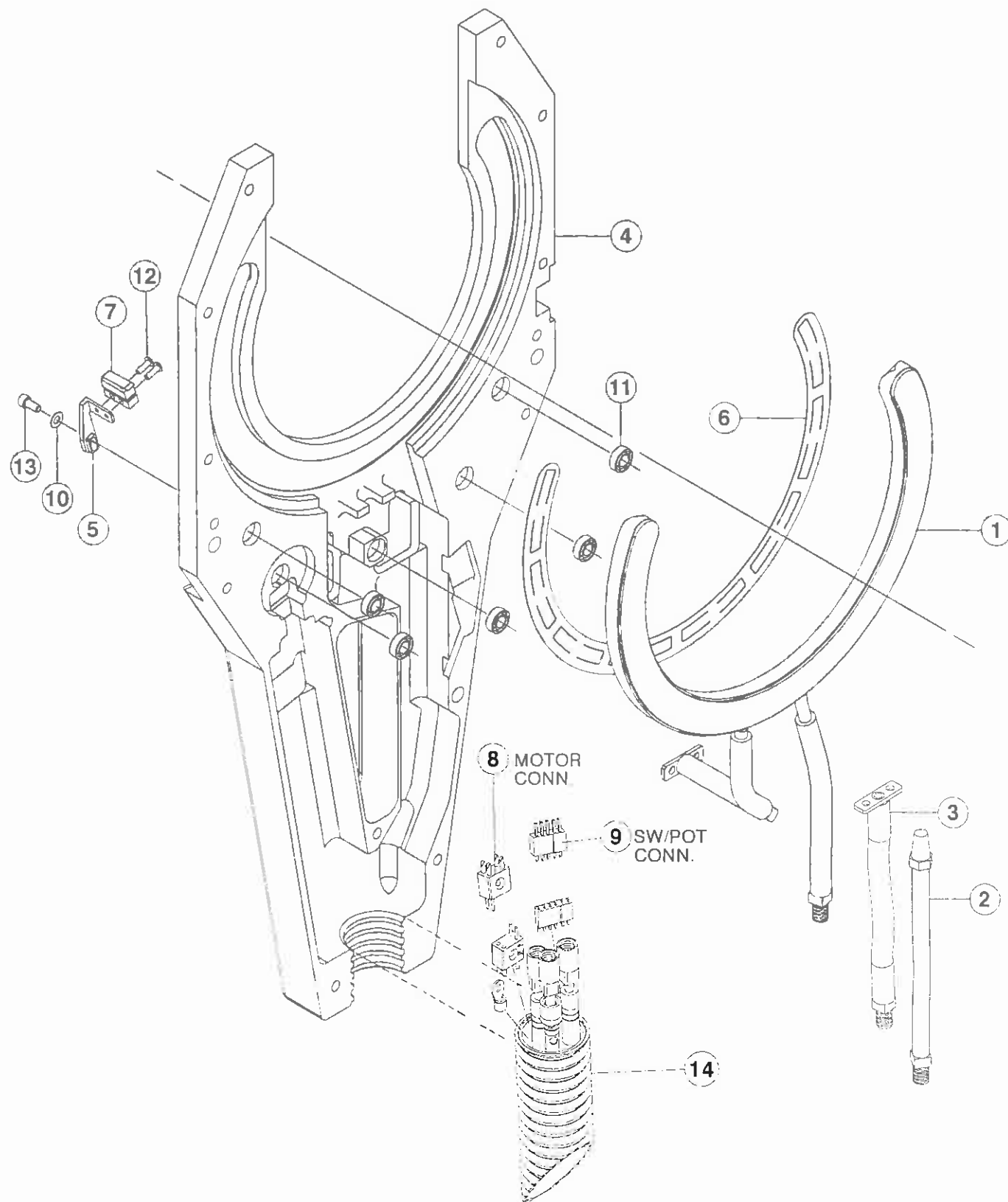

ITEM NO.	QTY.	PART NO.	DESCRIPTION
1	1	13080701-01	CONDUCTOR RING
2	1	13080709-01	FTG GAS LINE ASSY
3	1	13080801-01	CABLE GROUND
4	1	42080101-01	HOUSING COVER SIDE
5	1	42081102-01	BRACKET LIMIT SWITCH
6	1	42080707-01	SPRING LEAF BACK
7	1	MMGGD1L2C	SWITCH LIMIT LEAF LOW MOTION
8	1	JF2S2PCD	CONN 4 PIN JACK MINIATURE (GRY)
9	1	7051	CONN 5 PIN MALE SUB-MINIATURE BLK
10	1	DD621	WASHER BELLEVILLE .125 ID .25 D
11	5	SSRI6632LLRA3P25LY	BEARING BALL .18 .37 [15]
12	2	SBS02-56-0,25NP	SCREW 8TH SKT 2-56 1/4 L
13	1	SCS04-40-0,25NP	SCREW CAP SKT 4-40 1/4 L
14	1	13080800-01	CABLE ASSY

NOTE: ITEMS 6, 8, 10 & 13 ARE AVAILABLE AS A COMPLETE ASSEMBLY, PART NUMBER 13080803-01 (IPB # 080803).

MODEL 8-4000
IPB 080102
HOUSING COVER SIDE ASSEMBLY

ISSUED: 16 OCT 1996
REVISED: 4 AUG 2006

TO ORDER USE PART NUMBER.
PRICE, PART NUMBER AND DESCRIPTION
SUBJECT TO CHANGE WITHOUT NOTICE.

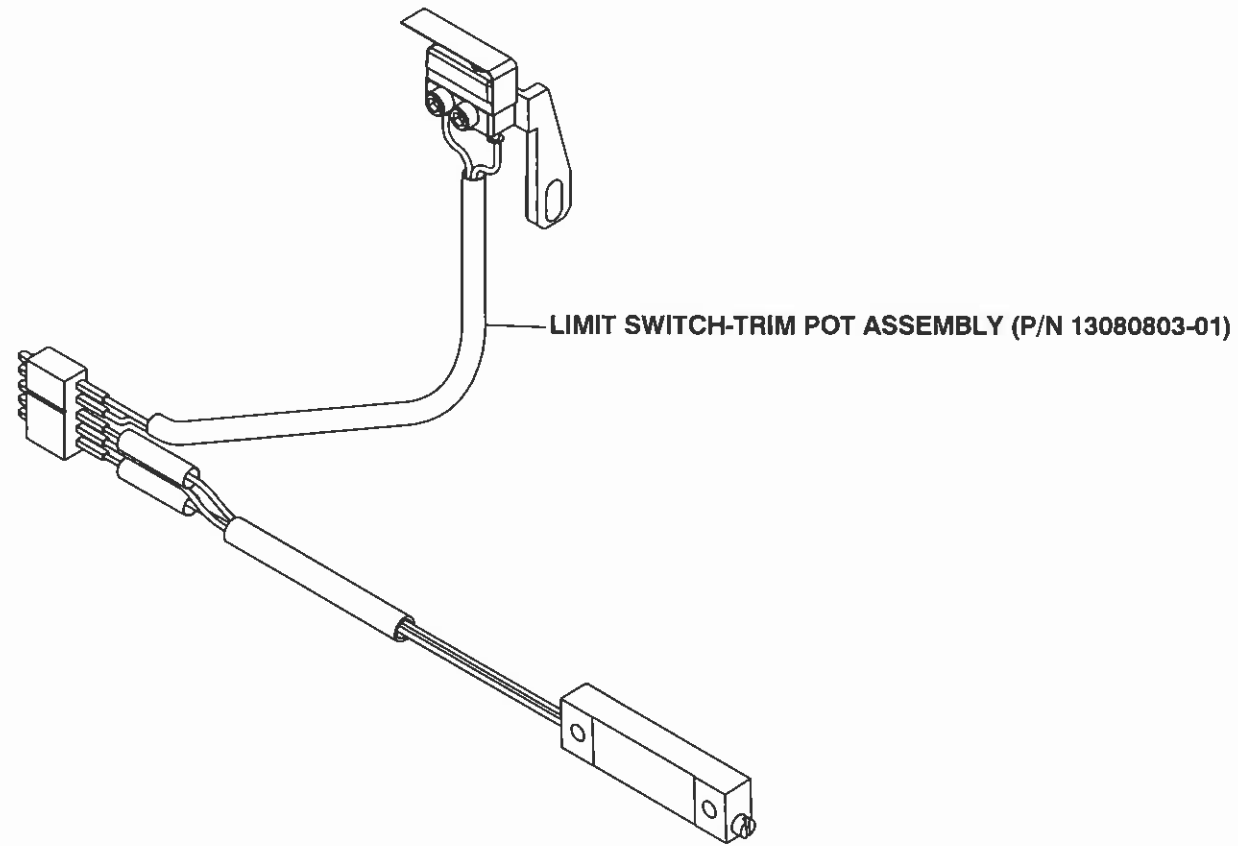

ITEM NO.	QTY.	PART NO.	DESCRIPTION
1	1	42081102-01	BRACKET LIMIT SWITCH
2	1	MMGGD1L2C	LIMIT SWITCH LEAF
3	2	SCS02-56-0,25NP	SCREW CAP SKT 2-56 1/4 L
4	1	3057L-1-202	POT TRIM 2K 1-1/4 MULTI TURN
5	1	7051	CONN 5 PIN MALE
6	1	RN55D7871F	RES 7.87K
7	1	RN55D1300F	RES 130 OHMS 1/4W
8	1	M23053-5-102-0	TBG SHRINK 1/16 ID BLK
9	1	M23053-5-102-0	TBG SHRINK 1/16 ID BLK
10	1	EXE-24-19-36-9	WIRE 24 AWG 19 STRD WHITE TEFLON INSUL
11	1	EXE-24-19-36-3	WIRE 24 AWG 19 STRD ORANGE TEFLON INSUL
12	2	M23053_5-104-0	TBG SHRINK 1/8 ID BLK

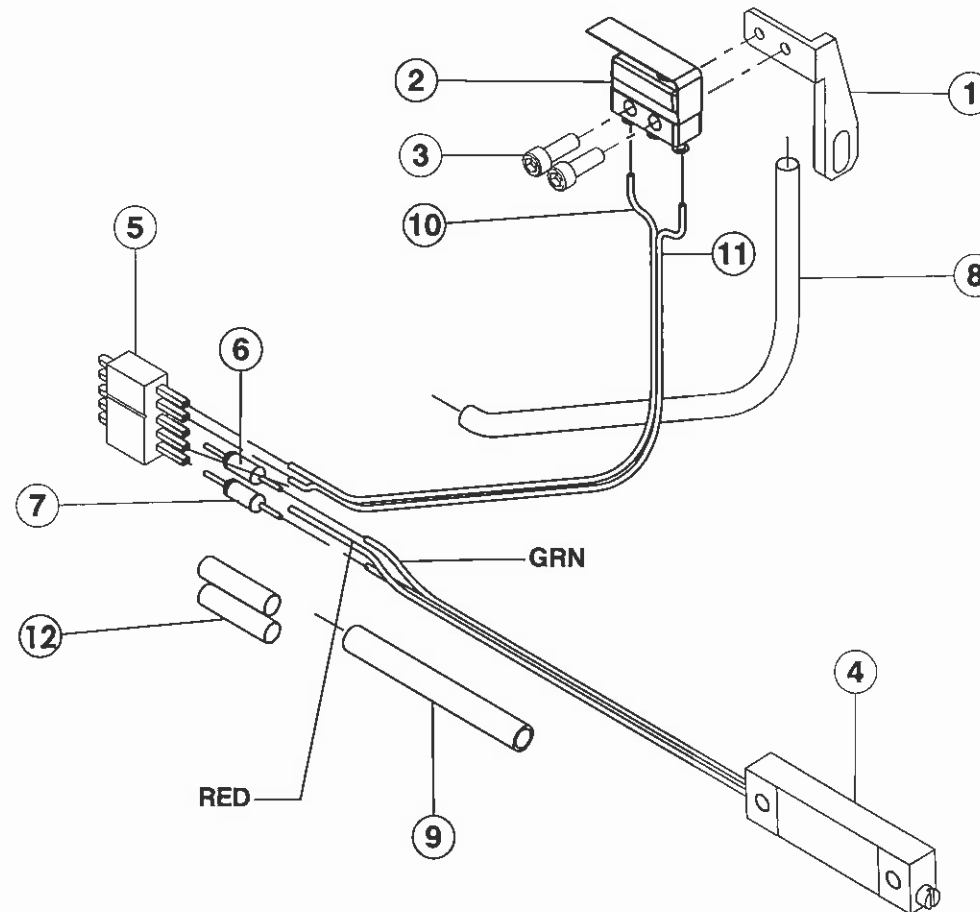

**MODEL 8
IPB 080803
LIMIT SWITCH-TRIM POT ASSEMBLY
(M8-2000, M8-4000 AND M8-6625)**

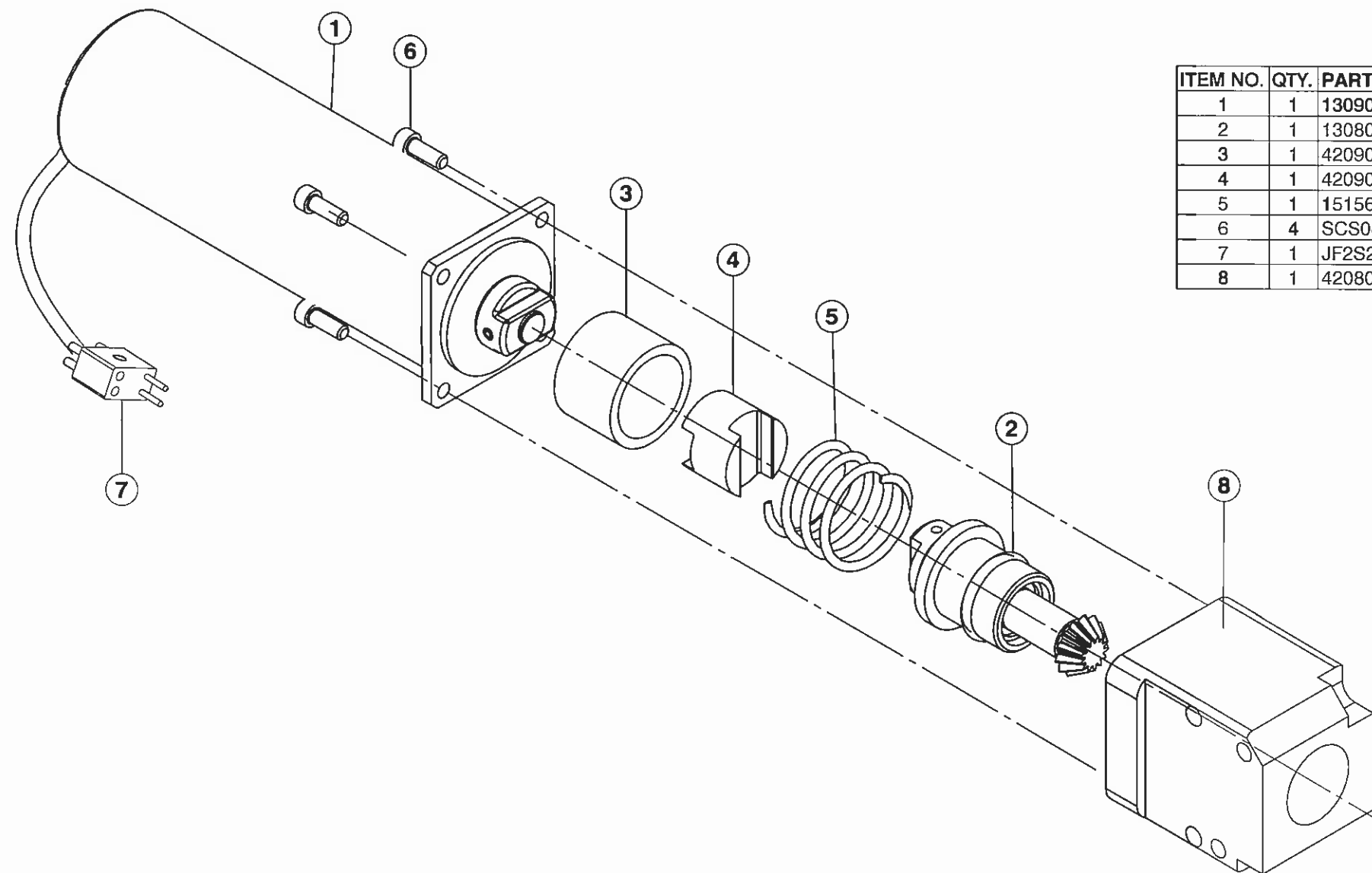

ITEM NO.	QTY.	PART NO.	DESCRIPTION
1	1	13090602-03	MOTOR DRIVE ASSY
2	1	13080602-01	DRIVE PINION ASSY
3	1	42090602-04	SPACER SPRING
4	1	42090602-03	COUPLING INSULATING DELRIN
5	1	15156	SPRING CPRSN .81D .70L .067W
6	4	SCS04-40-0,31NP	SCREW CAP SKT 4-40 5/16 L
7	1	JF2S2PCD	CONN 4 PIN JACK MINIATURE (GRY)
8	1	42080600-01	BLOCK MOTOR (NEW)

MODEL 8
IPB 080601
MOTOR DRIVE ASSEMBLY
(M8-2000, M8-4000 AND M8-6625)

ISSUED: 16 OCT 1996
REVISED: 25 JUL 2006

TO ORDER USE PART NUMBER.
PRICE, PART NUMBER AND DESCRIPTION
SUBJECT TO CHANGE WITHOUT NOTICE.

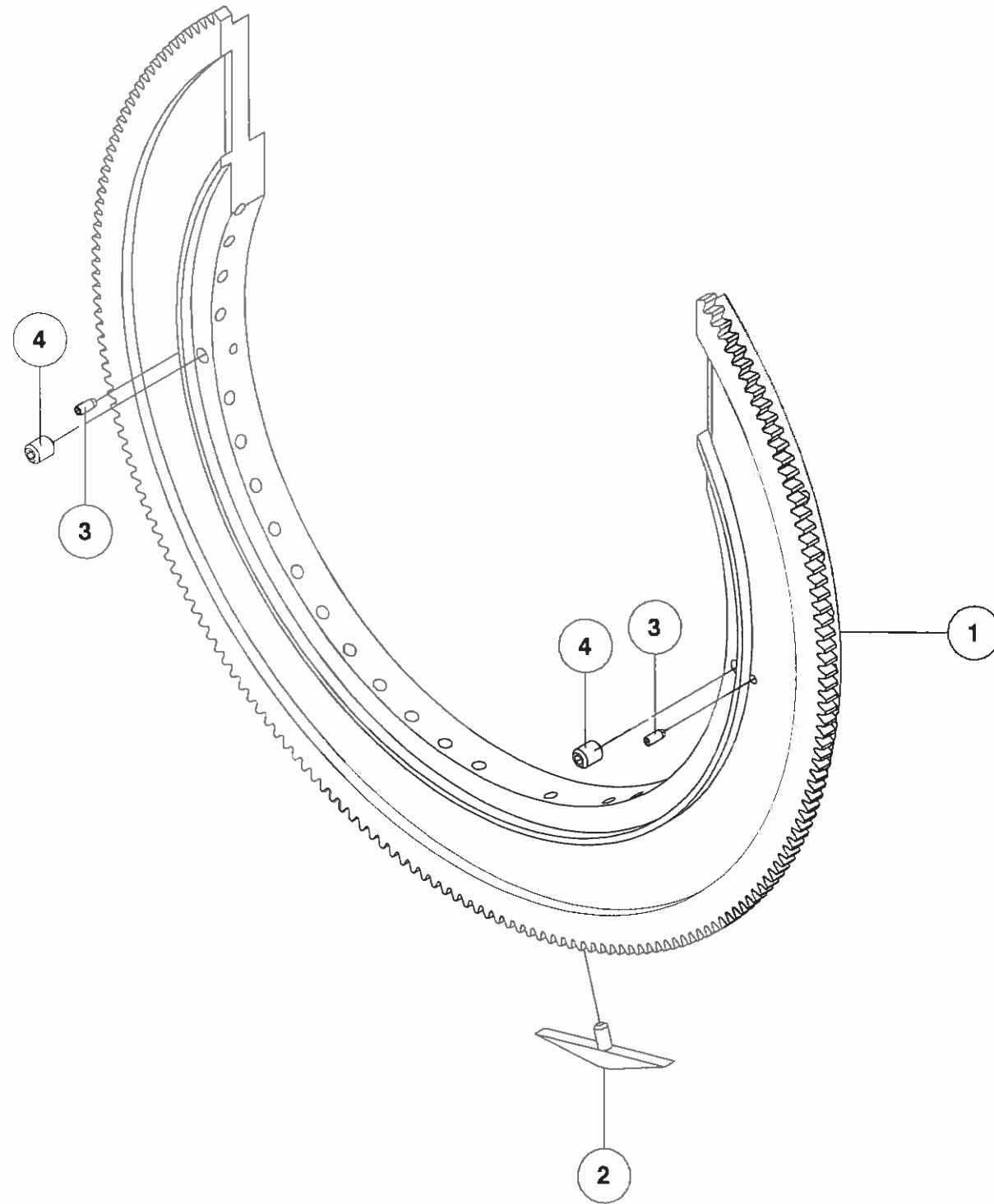

ITEM NO.	QTY.	PART NO.	DESCRIPTION
1	1	42080700-01	ROTOR
2	1	42080701-01	CAM LIMIT SWITCH
3	2	22080733-01	PIN ROLL 1/16D .15L (MODIFIED)
4	2	SSS06-32-18NPCU	SCREW SET SKT 6-32 3/16 L CUPT

MODEL 8-4000
IPB 080700
ROTOR ASSEMBLY

ISSUED: 16 OCT 1996
REVISED: 4 AUG 2006

TO ORDER USE PART NUMBER.
PRICE, PART NUMBER AND DESCRIPTION
SUBJECT TO CHANGE WITHOUT NOTICE.

THIS DOCUMENT OR DRAWING AND THE INFORMATION CONTAINED HEREIN IS THE PROPERTY OF ARC MACHINES, INC., IS PROPRIETARY, IS SUBMITTED AND RECEIVED IN CONFIDENCE, SHALL BE USED ONLY FOR THE PURPOSE FOR WHICH IT IS SUBMITTED AND SHALL NOT BE COPIED IN WHOLE OR IN PART WITHOUT THE PRIOR EXPRESS WRITTEN PERMISSION OF ARC MACHINES, INC.



ITEM NO.	QTY.	PART NO.	DESCRIPTION
1	1	13500110-04	DUST CAP ASSY
2	1	MS3106E18-1PF42	CONN 10 PIN STRAIGHT PLUG W/OUT ENDBELL
3	1	G1501N186A3A	CONN BACKSHELL
4	1	MS39056-3	CONN TELESCOPIC BUSHING
5	1	1351109-01	COUPLING Q/D ASSY MALE GAS FOR 1/4 TUBING
6	1	42060805-04	BOOT MALE GAS CLIP TYP Q/D
7	1	261-PG-05	NUT/SLEEVE SPRING 5/16 TBG
8	2	42060804-01	BOOT MALE POWER/GROUND
9	1	42060800-02	COUPLING Q/D 1/4 WATER FEMALE MOD (SM-251B)
10	1	SM-252B	COUPLING Q/D 1/4PT MALE BRASS WATER/POWER
11	2	42090806-01	TBG POLYU BRAIDED ETHER BASE (WATER USE) 1/4 ID 3/8 OD
12	2	NER7-95-36T	CABLE 01/08GA TINNED COPPER ROPE
13	1	44-P-YELLOW	TBG POLYETHYLENE YELLOW POLY-FLO 1/4 OD .040 WALL
14	1	AS200718	SPRING GUARD .34 OD 18.00 LG
15	1	CWT11943	CABLE 09/22GA SHLD 0.2700D 4TP+1 WHT
16	1	DUCT-0.87-50-G	CONDUIT GRY 0.87 ID
17	1	M23053/5-111-0	TBG SHRINK 1-1/2 ID BLK
18	1	2PF1	FTG 1/4-28 FEMALE
19	1	JF2P2SCD	CONN 4 PIN PLUG MINIATURE (GRY)
20	1	7052	CONN 5 PIN FEMALE SUB-MINIATURE BLK W/GOLD PINS
21	1	34119	TERM RING 16-14 #4
22	2	MS20995C25	LOCKWIRE .025 DIA
23	2	M23053/5-108-0	TBG SHRINK 1/2 ID BLK
24	2	ARC-1881	FTG WTR/PWR-CA CRIMP 1/4-28 BRASS SWIVEL NUT (FEM)
25	2	42060800-07	COUPLING HOSE/CABLE ASSY

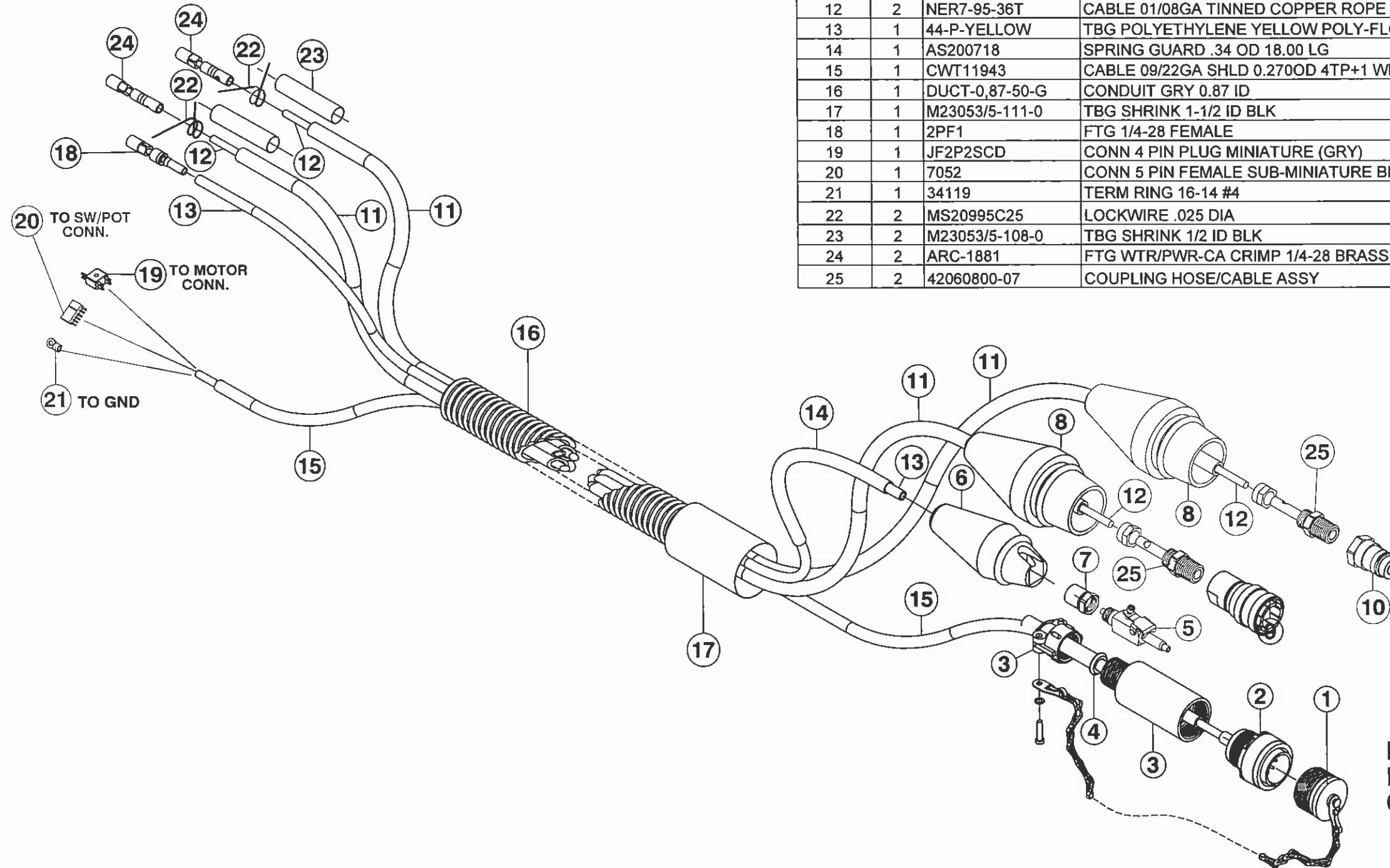

MODEL 8-4000 & 8-6625
 IPB 080800
 CABLE ASSEMBLY

ISSUED: 7 JUL 2003
 REVISED: 4 AUG 2006

TO ORDER USE PART NUMBER.
 PRICE, PART NUMBER AND DESCRIPTION
 SUBJECT TO CHANGE WITHOUT NOTICE.

ZONE	LTR	DCO	REVISIONS	DATE	BY	APPR

NOTES:

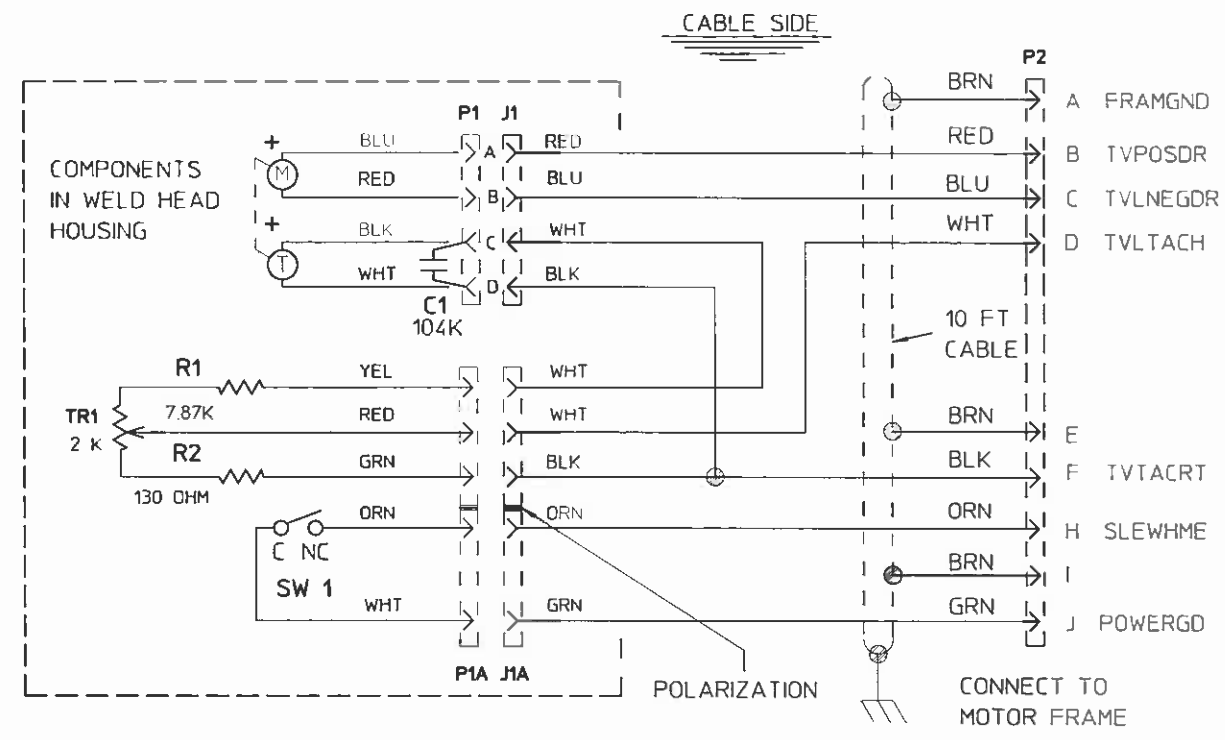

-01

CONNECTORS

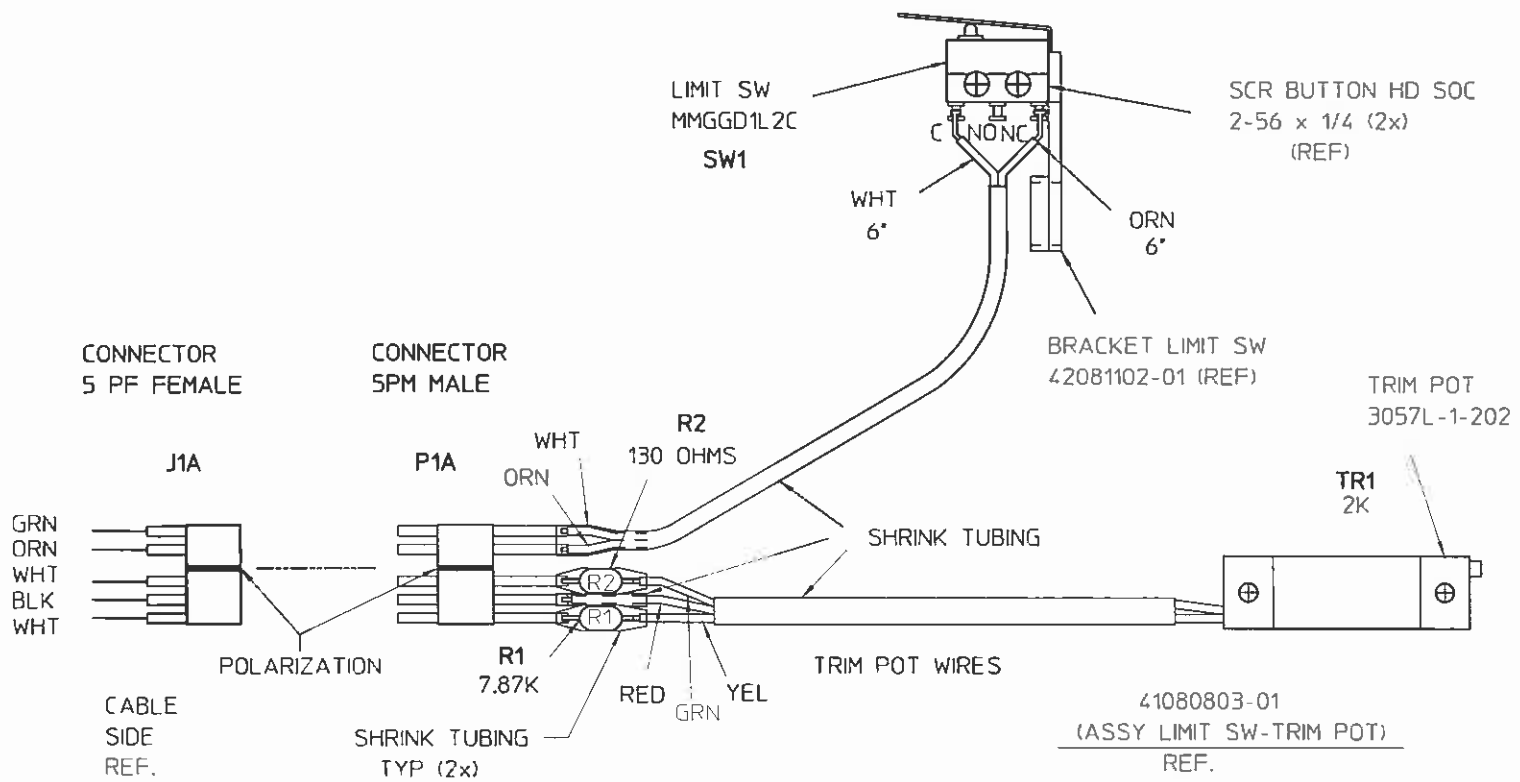
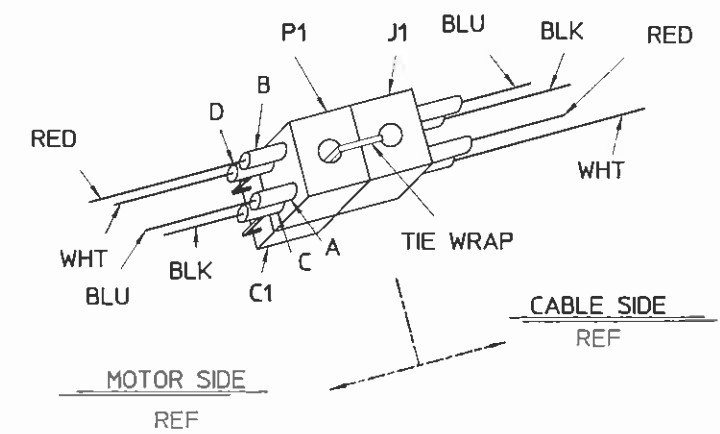

THIS DOCUMENT OR DRAWING AND THE INFORMATION CONTAINED HEREIN IS THE PROPERTY OF ARC MACHINES, INC. IS PROPRIETARY. IS SUBMITTED AND RECEIVED IN CONFIDENCE. SHALL BE USED ONLY FOR THE PURPOSE FOR WHICH IT IS SUBMITTED AND SHALL NOT BE COPIED IN WHOLE OR IN PART WITHOUT THE PRIOR EXPRESS WRITTEN PERMISSION OF ARC MACHINES, INC.

ALL MACHINED SURFACES TO BE <input checked="" type="checkbox"/>	THIRD ANGLE PROJECTION 	FOR IMPLIED STANDARDS SEE DDD-STD 100	ARC MACHINES, INC. DESCRIPTION MODEL 8-4000 WELDIAGRAM HEAD WIRING DIAGRAM	
	UNLESS OTHERWISE SPECIFIED ALL DIMENSIONS ARE IN INCHES. TOLERANCES ARE: FRACTIONS DECIMALS ANGLES 1/16 .X ± .030 ° .XX ± .010 .XXX ± .005	APPROVALS DRAWN: JONAS VYNIS CHECKED:		DATE 11JAN2001
	MATERIAL	APPR:		SIZE D MODEL NO. M-8 DRWG NO. 47081702 REV.
	NEXT ASSY. USED ON APPLICATION	QUOTATION		SCALE NONE DO NOT SCALE DRAWING SHEET 1 OF 1